

HAKKO FR-701 REPAIR SYSTEM

Repair System

Instruction Manual



Thank you for purchasing the HAKKO FR-701 Repair System.
Please read the manual before operating the HAKKO FR-701.
Keep this manual readily accessible for reference.



TABLE OF CONTENTS

1. PACKING LIST	1
2. SPECIFICATIONS	2
3. WARNINGS, CAUTIONS AND NOTES	3
4. PART NAMES (Soldering iron)	4
5. INITIAL SETUP (Soldering iron)	5
6. OPERATION (Soldering iron)	5
7. PARAMETER SETTING (Soldering iron)	9
8. MAINTENANCE (Soldering iron)	12
9. CHECKING PROCEDURE (Soldering iron)	13
10. ERROR MESSAGES (Soldering iron)	14
11. PART NAMES (Desoldering Tool)	15
12. INITIAL SETUP (Desoldering Tool)	16
13. OPERATION (Desoldering Tool)	18
14. PARAMETER SETTING (Desoldering Tool)	27
15. MAINTENANCE (Desoldering Tool)	35
16. CHECKING PROCEDURE (Desoldering Tool)	40
17. ERROR MESSAGES (Desoldering Tool)	42
18. TROUBLE SHOOTING GUIDE	43
19. TIP & NOZZLE STYLES	44
20. PARTS LIST	45
21. WIRING DIAGRAM	49

1. PACKING LIST

Please check to make sure that all items listed below are included in the package.

HAKKO FR-701 Station	1	HAKKO FR-4101 Desoldering Handpiece	
Power cord	1	with N61-05 (ø1.0mm) nozzle	1
HAKKO FX-8801 Soldering iron	1	HAKKO FH-410 Handpiece holder	1
HAKKO FH-800 Iron holder	1	Tool box	1
Cleaning wire	1	Instruction Manual	1

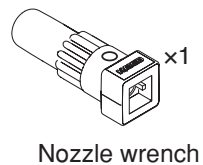
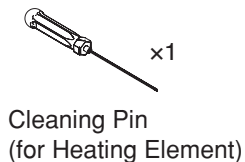
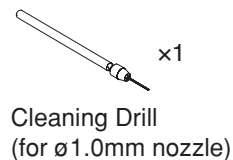
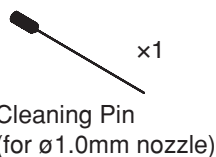
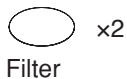
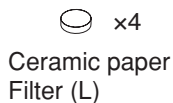
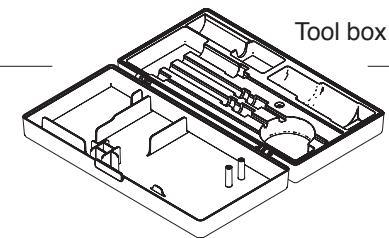
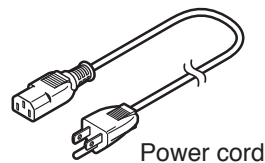
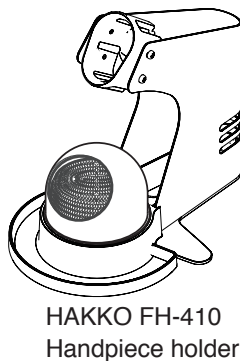
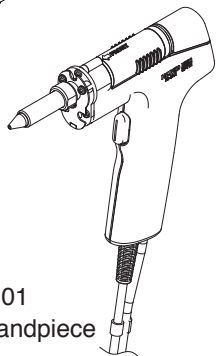
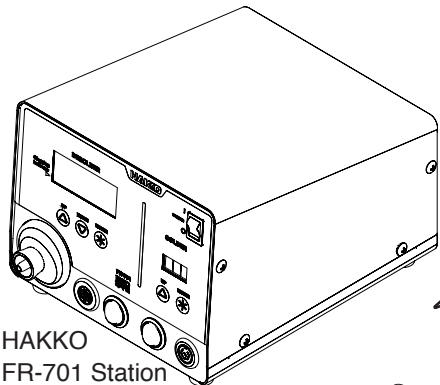

2. SPECIFICATIONS

Power consumption	260W
-------------------	------

● Station

Dimensions (W x H x D)	190(W) x 140(H) x 220(D) mm (7.5 x 5.5 x 8.7 in.)
Weight (w/o cord)	6.2 kg (13.7 lb.)

● Station (Soldering iron)

Output	AC26V
Temperature range	50 - 480°C (120 - 899°F)
Temperature stability	±1°C at idle temperature {When set to 200-480°C (400-899°F)}

● Station (Desoldering Tool)

Output	AC24V
Vacuum generator	Vacuum pump, double cylinder type
Vacuum pressure (max.)	80 kPa (600 mmHg)
Suction flow	15 L/min.
Temperature range	330 - 450°C (620 - 850°F)
Temperature stability	±5°C (9°F) at idle temperature

● HAKKO FX-8801

Power consumption	65W (26V)
Tip to ground resistance	< 2 Ω
Tip to ground potential	< 2 mV
Heating element	Ceramic heater
Cord	1.2 m (3.9 ft.)
Total length (w/o cord)	217 mm (8.5 in.) with B tip
Weight (w/o cord)	46 g (0.10 lb.) with B tip

● HAKKO FR-4101

Power consumption	140W (24 V)
Nozzle to ground resistance	< 2 Ω
Nozzle to ground potential	< 2 mV
Cord	1.2 m (3.9 ft.)
Length (w/o cord)	168 mm with N61-05 nozzle
Weight (w/o cord)	170 g with N61-05 nozzle

* The temperature was measured using the FG-101 thermometer.

* This product is protected against electrostatic discharge.

* Specifications and design are subject to change without notice.

■ Electrostatic Protection

This product includes such features as electrically conductive plastic parts and grounding of the unit as measures to protect the device to be soldered from the effects of static electricity. Be sure to observe the following instructions:

1. The plastic parts are not insulators, they are conductors. When making repairs or replacing parts, take sufficient care not to expose live electrical parts or damage insulation materials.
2. Be sure to ground the unit during use.

※ 各言語（日本語、英語、中国語、フランス語、ドイツ語、韓国語）の取扱説明書は以下のURL、HAKKO Document Portalからダウンロードしてご覧いただけます。
(商品によっては設定の無い言語がありますが、ご了承ください)

* 各国語言(日語、英語、中文、法語、德語、韓語)的使用說明書可以通過以下網站的HAKKO Document Portal 下載參閱。
(有一部分的產品沒有設定外語對應,請見諒)

* Instruction manual for the language, Japanese, English, Chinese, French, German and Korean can be downloaded from the following URL, HAKKO Document Portal.
(Please note that some language may not be available depending on the product.)



<https://doc.hakko.com>

中國RoHS: 產品中有毒有害物質或元素的名稱及含量

部件名稱	有毒有害物質或元素					
	鉛(Pb)	汞(Hg)	鎘(Cd)	六價鉻(Cr(VI))	多溴聯苯(PBB)	多溴二苯醚(PBDE)
焊鐵部	×	○	○	○	○	○
連接部	×	○	○	○	○	○
隔離器	×	○	○	○	○	○
電路板	×	○	○	○	○	○
插頭	×	○	○	○	○	○
插座	×	○	○	○	○	○
電磁蓋	×	○	○	○	○	○
真空泵組件	×	○	○	○	○	○
螺釘	×	○	○	○	○	○

○ : 表示該有毒有害物質在該部件所有均質材料中的含量均在SJ/T 11363-2006標準規定的限量要求以下。
× : 表示該有毒有害物質至少在該部件的某一均質材料中的含量超出SJ/T 11363-2006標準規定的限量要求。

3. WARNINGS, CAUTIONS AND NOTES

Warnings, cautions and notes are placed at critical points in this manual to direct the operator's attention to significant items. They are defined as follows:

 **WARNING:** Failure to comply with a WARNING may result in serious injury or death.

 **CAUTION :** Failure to comply with a CAUTION may result in injury to the operator, or damage to the items involved.

WARNING

When power is ON, the tip and nozzle will be hot. To avoid injury or damage to personnel and items in the work area, observe the following:

- Do not touch the tip and nozzle or the metal parts near the tip and nozzle.
- Do not allow the tip and nozzle to come close to, or touch, flammable materials.
- Inform others in the area that the unit is hot and should not be touched.
- Turn the power off when not in use, or left unattended.
- Turn the power off when changing parts or storing the HAKKO FR-701.
- This unit is for counter or workbench use only.
- This appliance can be used by children aged from 8 years and above and persons with reduced physical, sensory or mental capabilities or lack of experience and knowledge if they have been given supervision or instruction concerning use of the appliance in safe way and understand the hazards involved.
- Children shall not play with the appliance.
- Cleaning and user maintenance shall not be made by children without supervision.

To prevent accidents or damage to the HAKKO FR-701, be sure to observe the following:

CAUTION

- Do not use the unit for applications other than soldering or desoldering.
- Do not strike the handpiece against hard objects to remove excess solder. This will damage the handpiece.
- Do not modify the HAKKO FR-701.
- Use only genuine HAKKO replacement parts.
- Do not allow the HAKKO FR-701 to become wet, or use it when hands are wet.
- Be sure to hold the plug when inserting or removing the handpiece and power cords.
- Be sure the work area is well ventilated. Soldering and desoldering produces smoke.
- While using the HAKKO FR-701, don't do anything which may cause bodily harm or physical damage.

4. PART NAMES (Soldering iron)

● Station

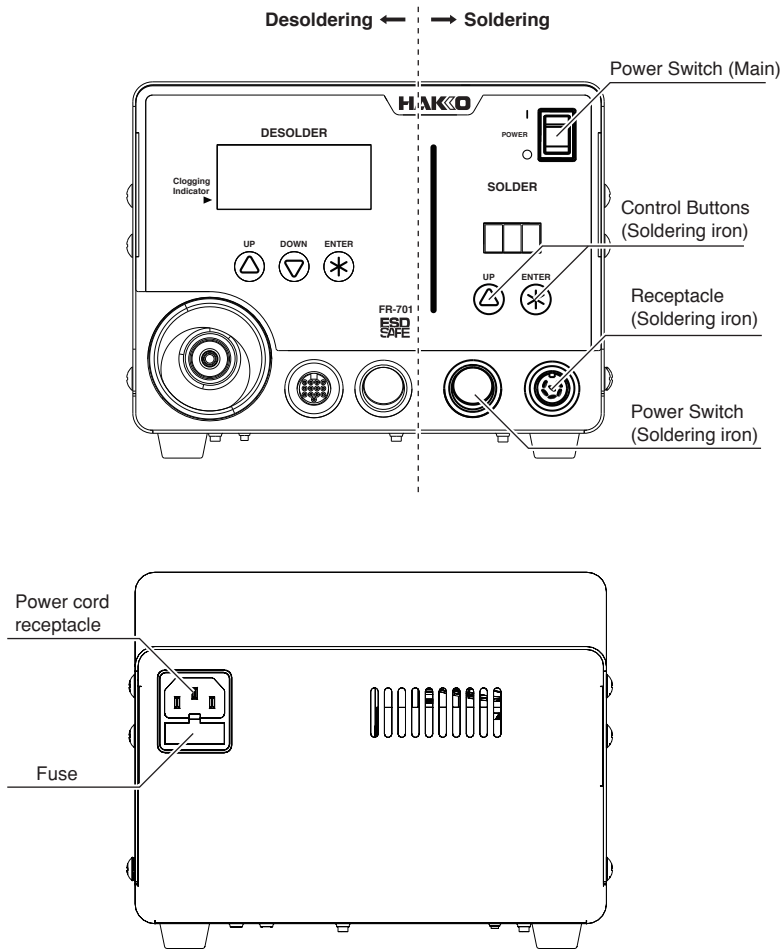

※Use this product with the following models. (Soldering iron)

- | | | |
|---|--------------------------------------|---|
| • HAKKO FX-8801
{Soldering iron (M)} | • HAKKO FX-8803
(Soldering gun) | • HAKKO FX-8805
{Soldering iron (L)} |
| • HAKKO FX-8802
(Soldering iron N ₂ Type) | • HAKKO FX-8804
(SMD Hot tweezer) | |

- When using the HAKKO FX-8802 / FX-8803 / FX-8804, please use the applicable iron holder.
- Each Hakko handpiece with the exception of the HAKKO FX-8801 / FX-8805 has their own instruction manual. Please refer to this manual for specifications and replacement parts.

● Soldering iron (HAKKO FX-8801)

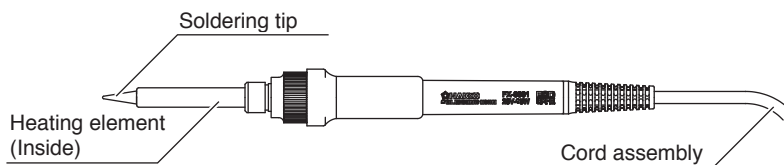

5. INITIAL SETUP (Soldering iron)

A. Setup the iron holder

1. Fit the small sponge pieces into the hollows of the iron holder base.
2. Add an appropriate amount of water into the iron holder base. The small sponge will absorb water and help keep the large sponge damp at all times.
3. Dampen the large sponge and place it on the iron holder base.

⚠ CAUTION

Be sure the sponge is moistened with water before use to avoid damaging the tip.

*When using a Cleaning Wire

Place it in the iron holder as shown on the right.

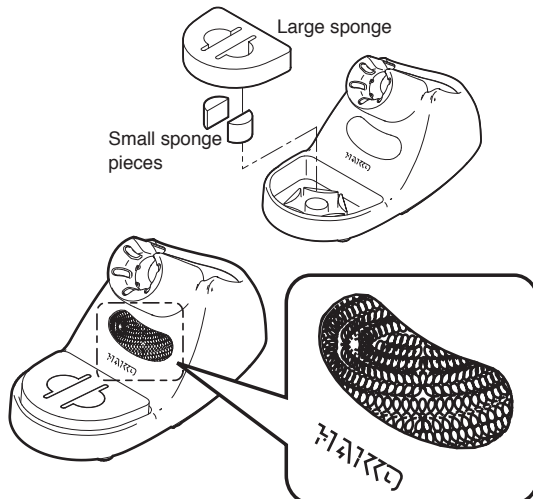

B. Connect the iron to the station

1. Connect the cord assembly to the receptacle.
2. Place the iron into the iron holder.
3. Plug the power cord into an appropriate power supply.

⚠ CAUTION

- Be sure to turn off the power before connecting or disconnecting the cord assembly for the iron to and from the receptacle to avoid damaging the circuit board.
- Do not use any iron other than those listed in Section 1 of this manual. Doing so may result in inadequate performance and / or possible damage to the unit.
- The unit is protected against electrostatic discharge and must be grounded for full efficiency.

Push on the plug until it stops, making sure it is securely connected.

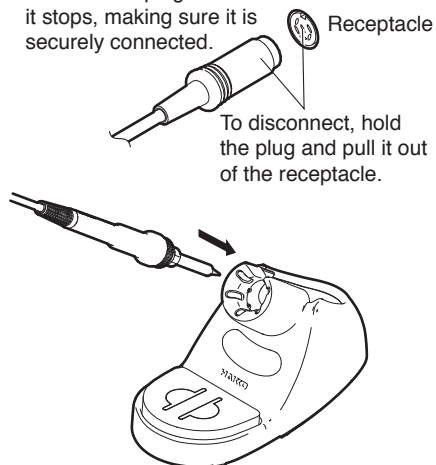

6. OPERATION (Soldering iron)

● Operation and indication

Switch and control button

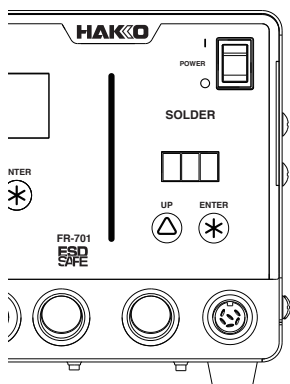

The front panel for the HAKKO FR-701 (Soldering iron) has the following two control buttons.

- ⚠ - Use this button to select and change settings.
In the temperature preset mode, pressing this button will change the selected preset temperature while the unit is in operation.
Pressing and holding the button will start the adjustment mode.
- * - Use this button to make and confirm selections.
Pressing this button will display the current set temperature.
Pressing and holding the button will start the temperature setting mode.

A. Operation

1. Turn on the power switch (main) located on the front.
2. Turn on the power switch (soldering iron).

After turning on the power switch, **888** will be displayed for two seconds, and current temperature will be displayed.

When the display stabilizes, the LED heater lamp will begin to flash.



LED heater lamp

⚠ CAUTION

Place the iron in the iron holder when not in use. Turn the power off when the HAKKO FR-701 is not in use for an extended period.

B. After use

Always clean the tip and coat it with fresh solder after use.

(Refer to "Tip Maintenance.")

● Making Changes to Settings

⚠ CAUTION

If no buttons are pressed for at least one minute during the process of changing settings of the unit, the system will exit and return to operating mode and display the current temperature.

A. Changing the set temperature

The temperature setting range is from 50 to 480°C. (from 120 to 899°F)

By default, the temperature is set to 350°C. (662°F)

Example : Changing from 350°C to 400°C

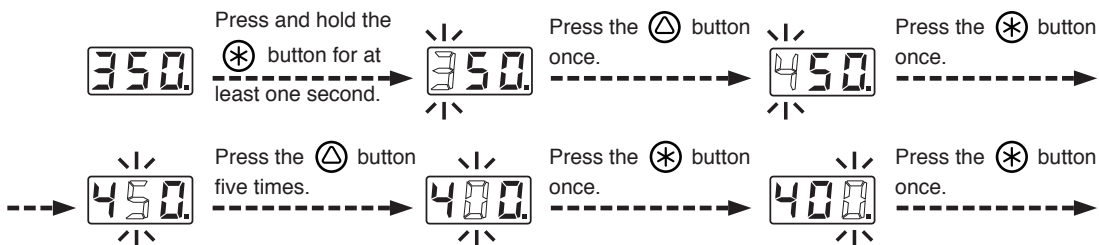

The desired temperature is saved to the system memory.

Heater control will begin after the new set temperature is displayed.

B. The preset mode

The HAKKO FR-701 (Soldering iron) has a preset mode that will allow the unit to store up to 5 preset temperatures you can change between instead of using the above normal mode.

Initial preset temperatures

P1: 250°C (482°F), P2: 300°C (572°F), P3: 350°C (662°F), P4: 400°C (752°F), P5: 450°C (842°F)

The initial number of active presets is set to 5 at the factory.

The default selected preset is set to P3 at the factory.

Example : Changing preset temperature from preset No.1 (250°C) to No.3 (350°C).

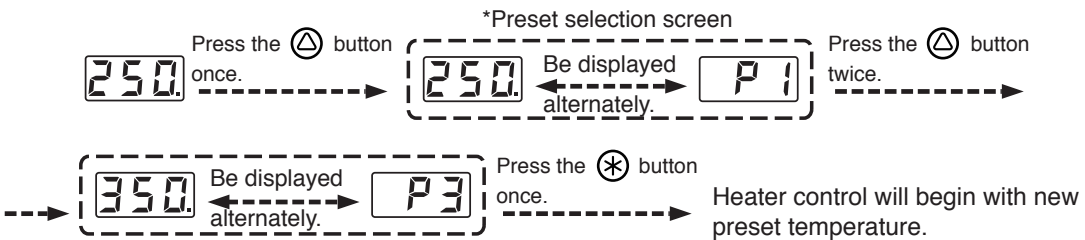

The procedure for making changes to the preset temperatures is the same with “A. Changing the set temperature” in 5. OPERATION (Soldering iron).

C. Performing the temperature adjustment

When replacing the iron, heater or tip, a temperature adjustment may be required.

Use adjustment mode to perform the temperature adjustment.

⚠ CAUTION

- Enter the observed value in the adjustment mode after the tip temperature stabilizes.
- The maximum single adjustment that can be made is $\pm 150^\circ\text{C}$ (270°F) relative to the set temperature. If a larger adjustment is needed, make the first adjustment at the maximum value of 150°C (270°F), then repeat the adjustment process.

Example : If the measured temperature is 380°C and the set temperature is 400°C .

1. Press and hold the \triangle button for at least two seconds.

- [Adj.] is displayed. When you press the \ast button, the display will move to the adjust mode.

2. Changing from [400] to [380].

- The procedure for changing the value in adjustment mode is the same as setting the temperature in normal mode. Please refer to Section 5 - OPERATION.

NOTE :

During adjustment mode, the hundreds digit will accept values from 0 through 6 if the temperature is set to display in $^\circ\text{C}$, or the values 0 through 9 if the temperature is set to display in $^\circ\text{F}$.

3. Press the \ast button to exit the setting after changing the values.

- The tip temperature will be adjusted accordingly.

* How to distinguish between Temperature Setting Mode and Adjustment Mode.

The display differs in the temperature setting and the adjustment mode.

In the Temperature Setting Mode

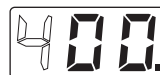

In the Adjustment Mode



Identification lamps are on in the adjustment mode.

⚠ CAUTION

Please be sure to confirm the status of the identification lamps so that you do not enter a value in the wrong mode.

D. Restriction on setting changes (Password function)

It is possible to restrict certain setting changes to the unit.

There are three choices for the password setting. (The factory default is "0 : Open")

	0 : Open	1 : Partial	2 : Restricted
Move to the parameter setting mode	○	×	×
Move to the temperature setting mode	○	△	×
Move to the preset selection mode	○	△	×
Move to the adjust mode	○	△	×

○ : You can make changes without entering a password.

△ : You can choose whether or not a password is needed to make changes.

× : A password is required to make changes.

Select and input three letters for password from six letters on the right.



The letters for password

Example: The procedure for changing the set temperature when the unit is restricted by a password.
(Password is "AbC")

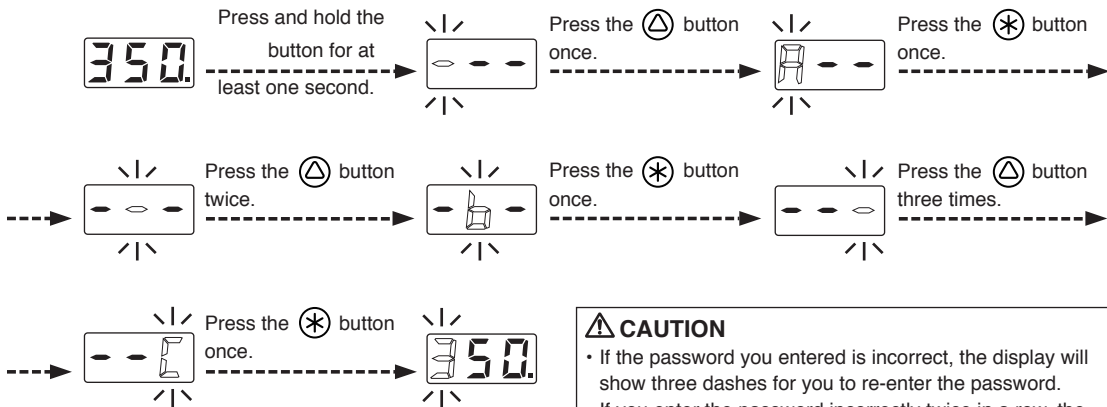

⚠ CAUTION

- If the password you entered is incorrect, the display will show three dashes for you to re-enter the password.
- If you enter the password incorrectly twice in a row, the display will return to the previous screen.

The unit will move to the change setting screen for each mode after entering the password.

Please change the setting for each mode according to the procedure.

Enter the parameter setting to change the mode. Please refer to [7. PARAMETER SETTING (Soldering iron)]

7. PARAMETER SETTING (Soldering iron)

The HAKKO FR-701 (Soldering iron) has the following parameters.

Parameter name	Parameter No.	Value	Initial value
°C / °F selection	01	°C / °F	°C
Low temperature error setting	03	30 ~ 150°C (54 ~ 270°F)	150°C
Setting mode selection	11	0 : The normal mode / 1 : The preset mode	0
The number of preset*1		<input type="text" value="2P"/> (2 pcs.) ~ <input type="text" value="5P"/> (5 pcs.)	<input type="text" value="5P"/>
Password setting	14	0 : Open / 1 : Partial / 2 : Restricted	0
Temperature setting mode*2		<input type="text" value="10"/> : ○*4 / <input type="text" value="11"/> : ×*4	<input type="text" value="11"/>
Preset selection mode*2		<input type="text" value="20"/> : ○*4 / <input type="text" value="21"/> : ×*4	<input type="text" value="20"/>
Adjust mode*2		<input type="text" value="30"/> : ○*4 / <input type="text" value="31"/> : ×*4	<input type="text" value="31"/>
Password*3		<input type="text" value="A"/> <input type="text" value="b"/> <input type="text" value="c"/> <input type="text" value="d"/> <input type="text" value="E"/> <input type="text" value="F"/> Select three letters	-

*1 It is displayed only when "1:Preset mode" is selected in the setting mode.

*2 It is displayed only when "1:Custom" is selected in the password setting.

*3 It is displayed only when either "1:Custom" or "2:valid" is selected in the password setting.

*4 ○ : Password not required × : Password required

● 01: °C or °F temperature display selection

The displayed temperature can be switched between Celsius and Fahrenheit.

● 03: Low temperature error setting

If the sensor temperature goes below the low-limit temperature although heating element is on, an error will be displayed.

● 11: Setting mode selection

Temperature setting can be switched between the normal mode and the preset mode.

If selecting the preset mode, you will be asked for the number of preset you required.

Press the  button to set the number.

● 14: Password setting

Select "Open", "Partial" or "Restricted" for password setting. If selecting the Restricted, perform the setting for password. If selecting the partial, choose whether or not the password function is needed when moving to the temperature setting mode, the preset mode and the adjust mode and set the password.

● Parameter entering mode

1. Turn off the power switch.
2. Turn on the power switch while pressing the  button.
3. When the display shows , the station is in parameter entering mode.

A. °C or °F temperature display selection

1. Either or will be displayed if you press the button when is displayed.
2. and will be switched alternately if you press the button.
3. The display will return to if you press the button after selecting.

B. Low temperature error setting

1. Press the button to change the display to .
2. The low-limit temperature will be displayed if you press the button. Enter the value in the same manner as described in the normal mode [5. OPERATION "A. Changing the set temperature"].
3. The display will return to if you press the button after setting.

C. Setting mode selection

1. Press the button to change the display to .
2. If you press the button, the display will move to the setting mode selection screen. If you press the button, (The normal mode) and (The preset mode) will be switched alternately.
3. The display will return to if you press the button after selecting.*

*** If you select the preset mode, the display will move to the preset selection screen.**

4. The number of active preset will be displayed if you press the button at 3.
(Example : If the number is three, is displayed.)
5. Press the button to change the value and select the number of active preset you required.
The unit will accept values from 2 through 5.
6. The display will return to if you press the button after selecting.

D. Password setting

1. Press the \triangle button to change the display to 14 .
2. If you press the \ast button, the display will move to the setting mode selection screen.
If you press the \triangle button, 0 (Open), 1 (Partial) and 2 (Restricted) will be switched alternately.
3. If you press the \ast button after selecting, the display will return to 14 . *1、2

***1 The display will move to the following selection screen if you select 1 (Partial).**

4. If you press the \ast button at 3, you will be asked whether or not the password function is needed when moving to the temperature setting mode.
5. Either 0 (without password) or 1 (with password) will be displayed if you press the \triangle button.
6. If you press the \ast button after selecting, you will be asked whether or not the password function is needed when moving to the preset selection mode.
7. Either 0 (without password) or 1 (with password) will be displayed if you press the \triangle button.
8. If you press the \ast button after selecting, you will be asked whether or not the password function is needed when moving to the adjust mode.
9. Either 0 (without password) or 1 (with password) will be displayed if you press the \triangle button.
10. If you press the \ast button after selecting, the display will move to password setting screen.

***2 If you select 2 (Restricted), the display will move to the following password setting screen. If you select 1 (Partial), the display will move to the following password setting screen after selecting *1.**

11. The hundreds digits in the display will begin to flash. It indicates that you can enter the value.
Press the \triangle button to enter the letter you required.
12. The tens digits in the display will begin to flash if you press the \ast button after entering.
Use the same procedure to enter the letters for tens and units digit.
13. The display will return to 14 if you press the \ast button after entering the units digit.

After changing parameters, press and hold the \ast button down for at least two seconds until 4 is displayed. At this time, you can switch between 4 and n by pressing the \triangle button. Select 4 if you are finished making changes or n if you need to go back and make more changes. Press the \ast button to confirm you selection.

**Changes will not be completed until 4 is displayed and you press the \ast button.
Please note that no changes will be made if you turn off the power while making changes.**

8. MAINTENANCE (Soldering iron)

Performing proper and periodic maintenance extends product life. Efficient soldering depends upon the temperature, quality and quantity of the solder and flux.

Apply the following service procedure as dictated by the conditions of usage.

⚠ WARNING

Since the soldering iron can reach a very high temperature, please work carefully. Except the case especially indicated, always turn the power switch OFF and disconnect the power plug before performing any maintenance procedure.

● Tip Maintenance

1. Set the temperature to 250°C (482°F).
2. When the temperature stabilizes, clean the tip with the cleaning sponge and check the condition of the tip.
3. If the solder plated part of the tip is covered with black oxide, apply fresh solder containing flux, and clean the tip again. Repeat until all the oxide is removed, then coat the tip with fresh solder.
4. If the tip is deformed or heavily eroded, replace it with a new one.

⚠ CAUTION

Do not file the tip in an attempt to remove the black oxide.

■ Cleaning the tip using the iron holder

1. Using the cleaning sponge

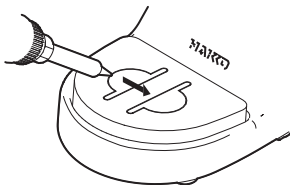

Use the cleaning sponge that comes with the product to clean the tip. It offers wide-ranging uses, from simple removal of excess solder to complete elimination of matter occurring as a result of oxidization.

2. Using the cleaning wire

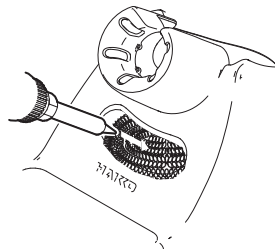

Material that is not removed easily with the cleaning sponge can likely be removed using the cleaning wire.

9. CHECKING PROCEDURE (Soldering iron)

Disconnect the plug of the cord assembly and measure the resistance value between the pins of the connecting plug as follows.

If the values of “a” and “b” are outside the value in the table, replace the heating element (sensor) and/or cord assembly.

If the value of “c” is over the value in the table, remove the oxidization film by lightly rubbing with sand-paper or steel wool the points shown in the drawing on the right.

a. Between pins 4 & 5 (Heating Element)	2.5 – 3.5 Ω (at time of room temperature)
b. Between pins 1 & 2 (sensor)	43 – 58 Ω
c. Between pin 3 & Tip	2 Ω or less

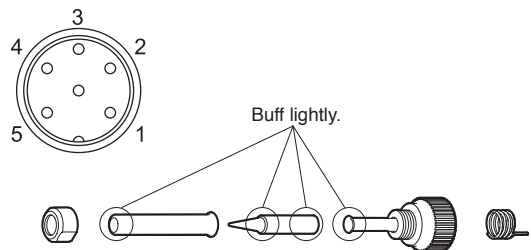

A. Broken Heating Element/Sensor

● Disassembling

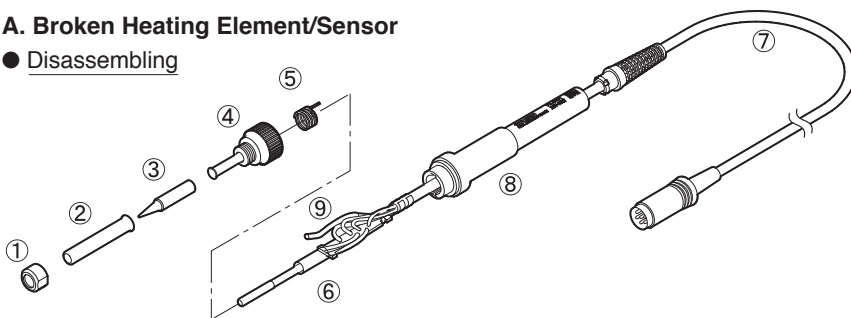

1. Turn the nut ① counterclockwise and remove the tip enclosure ② and the tip ③.
2. Turn the nipple ④ counterclockwise and remove it from the iron.
3. Pull both the heating element ⑥ and the cord assembly ⑦ out of the handle ⑧. (Toward the tip of the iron).
4. Pull the grounding spring ⑤ out of the sleeve of the terminal ⑨.

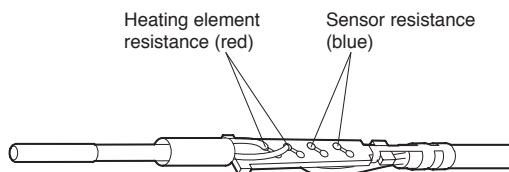

*Measure when the heating element is at room temperature.

1. Heating element resistance (red) 2.5 – 3.5 Ω
2. Sensor resistance (blue) 43 – 58 Ω

If the resistance value is not normal, replace the heating element. (Refer to the instructions included with the replacement part.)

After replacement

1. Measure the resistance between pins 4 and 1, 4 and 2, 5 and 1, and 5 and 2. If it is not ∞, the heating element and sensor are touching. This will damage the circuit board.
2. Measure the resistance “a,” “b,” and “c” to confirm that the leads are not twisted and that the grounding spring is properly connected.

B. Broken Cord Assembly

There are two methods of testing the cord assembly.

1. Turn the unit ON and set the temperature control knob to 480°C. Then bend the iron cord at various locations along its length, including in the strain relief area. The cord assembly needs to be replaced if S-E is displayed or although the LED heater lamp flashes, the tip temperature doesn't rise.

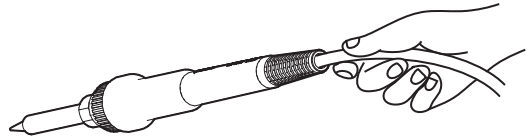

⚠ CAUTION

The power lamp starts to flash when the temperature reaches 480°C (880°F) regardless of the condition of the cord.

2. Check the resistance between the plug pin and the terminal lead.

Pin 1: Red Pin 2: Blue Pin 3: Green Pin 4: White
Pin 5: Black
Resistance: 0 Ω.

If it is higher than 0 Ω or is ∞, the cord should be replaced.

10. ERROR MESSAGES (Soldering iron)

● Sensor Error



When there is the possibility that a failure has occurred in the sensor or heater (including the sensor circuit), **S-E** is displayed and the power is shut down.

⚠ CAUTION

The sensor error also occurs if the tip is not inserted properly.

● Low-temperature alarm tolerance error



If the sensor temperature falls below the difference between the current temperature setting and the low-temperature alarm tolerance, **H-E** is displayed and the warning buzzer sounds. When the tip temperature rises to a value within the set tolerance, the buzzer will stop sounding.

EXAMPLE:

350°C (400°C - 50°C)
Set temperature | Low-temperature alarm tolerance
OR
650°F (750°F - 100°F)
Set temperature | Low-temperature alarm tolerance

EXAMPLE:

Assume that the temperature setting is 400°C/750°F and the tolerance 50°C/100°F. If the temperature continues to decrease and finally falls below the value indicated below while the heating element is on, the displayed value starts blinking to indicate that the tip temperature has dropped.

11. PART NAMES (Desoldering Tool)

● Station

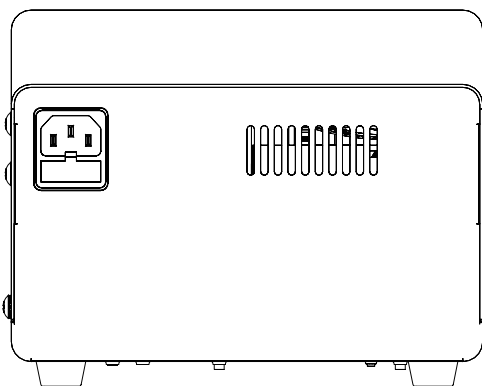
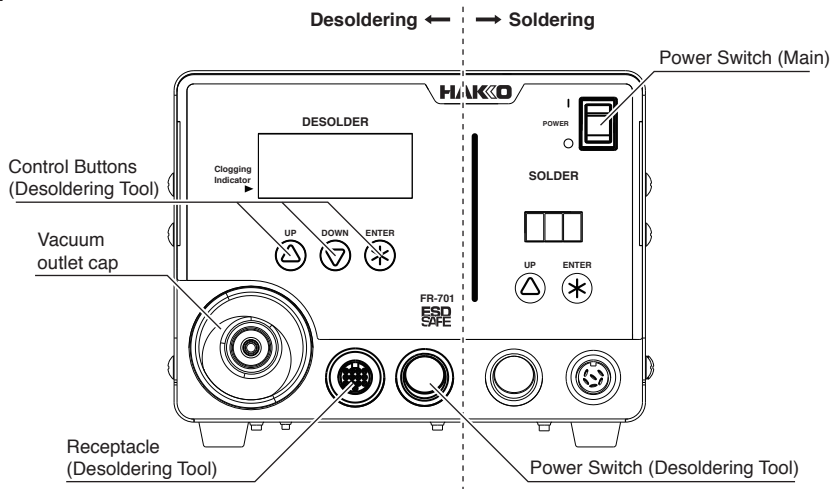

● Handpiece (HAKKO FR-4101 Desoldering Tool)

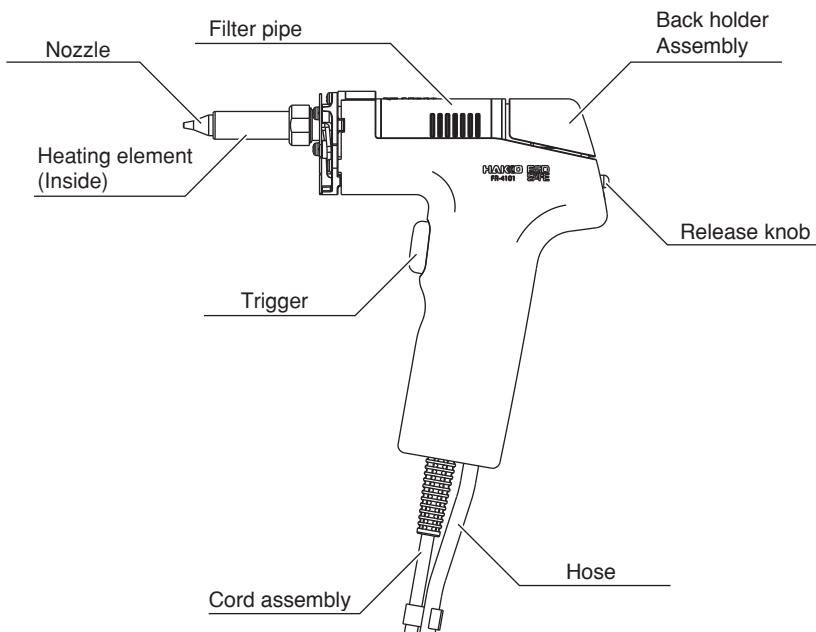

12. INITIAL SETUP (Desoldering Tool)

A. Handpiece holder

Loosen the adjusting screws to change the angle of the handpiece receptacle as you like, then tighten the screws.

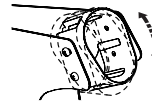

⚠ CAUTION

Increasing the angle of the handpiece receptacle will cause an increase in the handpiece temperature.

● Setup the handpiece holder

Following the instructions given in the illustration on the right, assemble the handpiece holder.

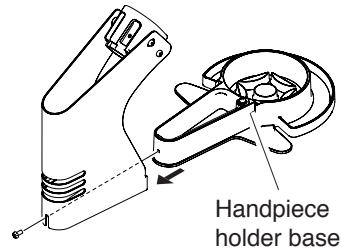
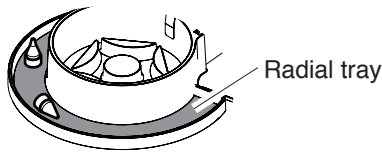

NOTE :

You can put nozzles that are not in use on the radial tray of the handpiece holder base.

● Cleaning wire

Following the instructions given in the illustration on the right, put the cleaning wire on the handpiece holder base.

Operation:

First, remove any excess solder from the nozzle by thrusting the nozzle into the cleaning wire.

(Do not wipe the nozzle against the wire. This may cause molten solder to spatter.)

When the wire becomes dirty or loaded with solder, reposition the wire until a clean surface is presented. When changing the cleaning wire, lift the case top vertically to prevent solder debris from falling out.

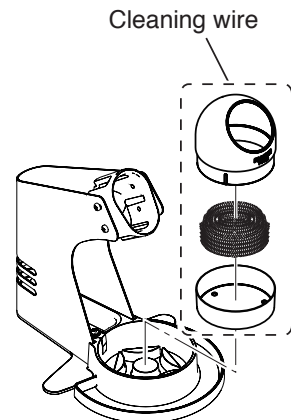

⚠ CAUTION

Be sure to hold the plug when inserting or removing the handpiece cord.

B. Station

● Connection

1. Connect the power cord to the receptacle on the rear of the station.
2. Connect the plug from the HAKKO FR-4101 to the receptacle on the HAKKO FR-701 (Desoldering Tool).

⚠ CAUTION

Connect the plug to the receptacle, aligning the tab on the plug with the opening on the receptacle.

3. Set the HAKKO FR-4101 in the handpiece holder.

4. Connect the hose from the HAKKO FR-4101 to the vacuum outlet cap on the HAKKO FR-701 station.

5. Plug the power cord into a grounded power outlet. Ensure that the power switch is OFF before plugging in the power cord.

⚠ CAUTION

Be sure to ground this product as it is ESD safe by design.

6. Turn the power switch (main) ON.

7. Turn the power switch (desoldering tool) ON.

Insert the plug into the receptacle until it seats.

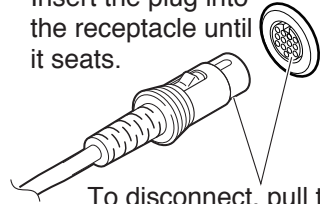

To disconnect, pull the plug from the receptacle while pressing down the tab on the plug.

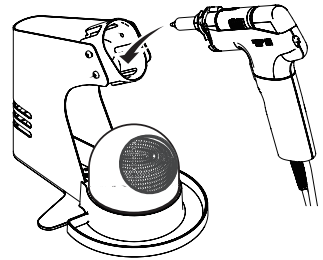

Connect the hose.

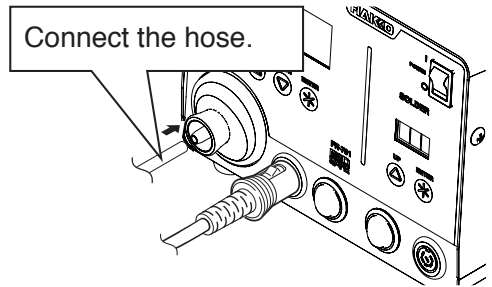

Turn the power switch (main) ON.

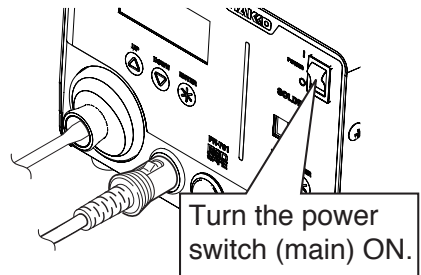

Turn the power switch (desoldering tool) ON.

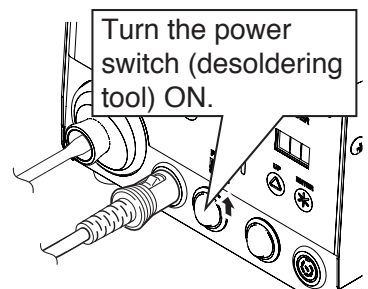

13. OPERATION (Desoldering Tool)

● Operation and indication

Switch and control button

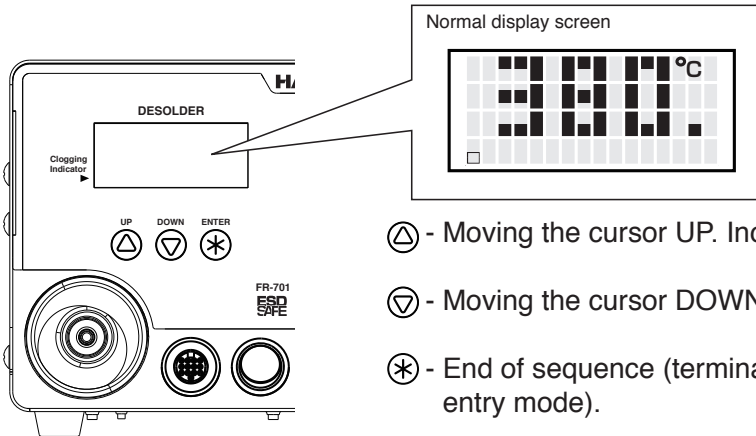

- △ - Moving the cursor UP. Increases the value.
- ▽ - Moving the cursor DOWN. Decreases the value.
- * - End of sequence (terminates a phase of a data entry mode).

A. Desoldering

⚠ CAUTION

If the pump does not operate, immediately clean the nozzle & heating element and replace the filter if necessary.

1. Place the nozzle over the lead wire of the part to be desoldered and begin heating.

Be careful to heat the lead wire and the solder, not the land. Placing the nozzle directly in contact with the land may cause the land to peel off. You may apply a small amount of solder to form a heat bridge to help the heating process.

2. Check to make sure all of the solder on the joint has melted.

With the nozzle still in place over the lead wire, slowly move the lead wire, being careful not to apply too much force. If the lead wire moves easily, all of the solder has melted.

3. Pull the trigger to remove the melted solder.

Make sure that a filter has been inserted in the desoldering tool. Desoldering without a filter may damage the pump.

4. If the solder was not removed, re-solder the part using new solder and then repeat the desoldering process.

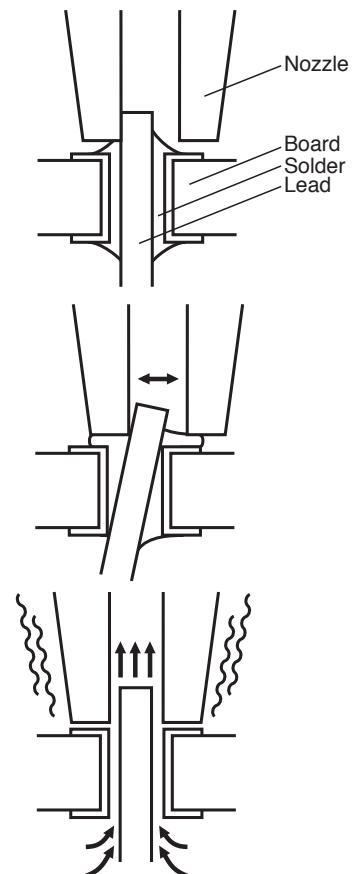

● **When triggering before the heater reaches set temperature**

When triggering before the heater reaches set temperature, the display screen shows “HEATING PLEASE WAIT” and the vacuum does not work.

Please wait for the heater to reach the set temperature.



B. Making Changes to Settings

● **Selecting the preset number**

The HAKKO FR-701 (Desoldering Tool) has a preset mode.

1. Press any of the three control buttons.

2. The preset selection screen appears.

▶PRESET1	350°C
PRESET2	400°C
PRESET3	450°C
<↑>	<↓>
<ENT>	

If you wish to exit the PRESET SELECTION screen, simply use the DOWN button to scroll to the bottom of the list, and select <EXIT>.

3. Make your SELECTION by moving the cursor UP or DOWN by pressing the corresponding buttons.

▶PRESET1	350°C
PRESET2	400°C
PRESET3	450°C
<↑>	<↓>
<ENT>	

4. Press the <ENT> button to finalize your selection.

▶PRESET1	350°C
PRESET2	400°C
PRESET3	450°C
<↑>	<↓>
<ENT>	

If you wish to exit the PRESET SELECTION screen...

- Select <EXIT> and press the <ENT> button. You will return to the normal display screen without making any changes.
- If the device is left alone without making any operation for 10 seconds, you will return to the normal display screen.

When changing the current set temperature or the preset temperature, follow the operation of “● Changing various setting (other than preset selections)”.

● Changing various settings (other than preset selections)

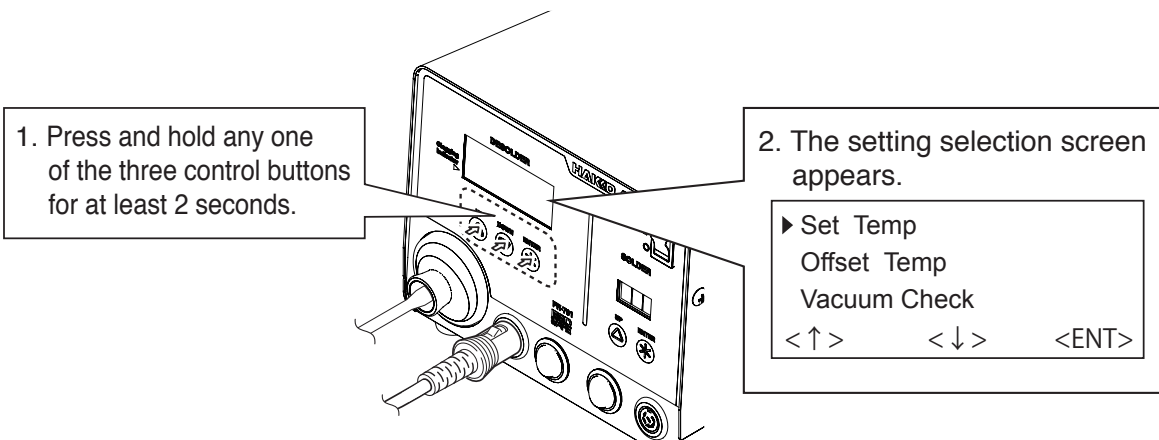

The following settings can be changed from this screen:

- | | |
|--------------|--|
| Set Temp | (Nozzle temperature setting) |
| Offset Temp | (Nozzle temperature offset setting) |
| Vacuum Check | (Check of nozzle clogging and suction force) |
| Preset Temp | (Setting of each preset temperature) |
| Preset ID | (Setting of each preset name) |
| LCD Contrast | (Contrast adjustment of display screen) |
| <EXIT> | (Return to the setting screen) |

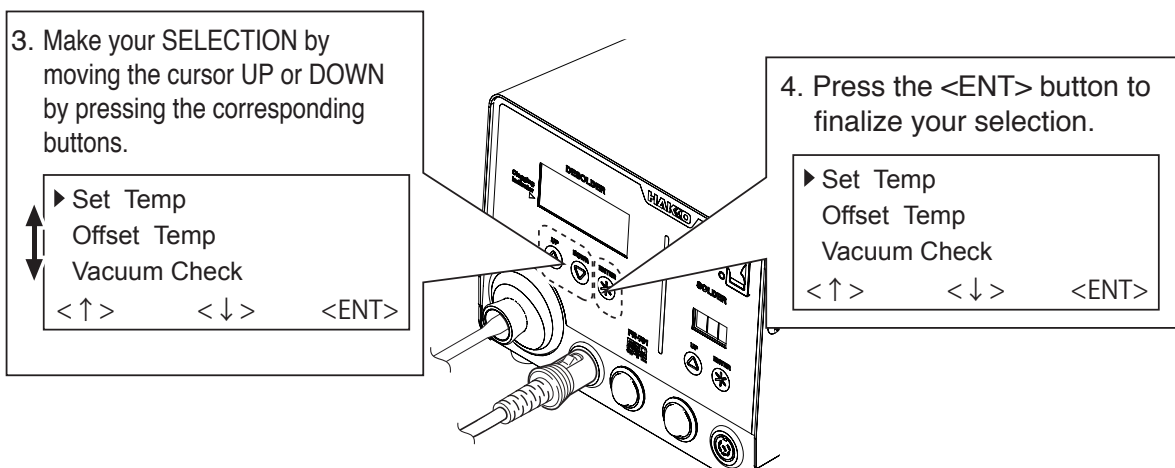

※Change of selected setting

Depending on selected setting, the display on the screen differs. However, you can make changes to the settings by following the above operation procedure. After completing the changes to the setting, if you press the ENTER button again in the selection screen, you will return to the normal display.

● Set Temp

⚠ CAUTION

The temperature range is from 330 to 450°C. (620 to 850°F)

- If you enter a value outside the temperature setting range, the display returns to the hundreds digit, and you have to enter a correct value.

1. Move the cursor to select “Set Temp”. After selecting, press <ENT>.

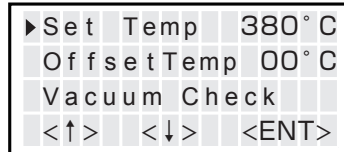

2. Entering from hundreds to units digit

Press the <↑> or <↓> to set the desired figure.

Only values from 3 to 4 can be selected when entering the hundreds digit.

(In °F mode, values from 6 to 8 can be selected.)

Values from 0 to 9 can be selected when entering the tens or units digits.

(The same values can be selected in °F mode.)

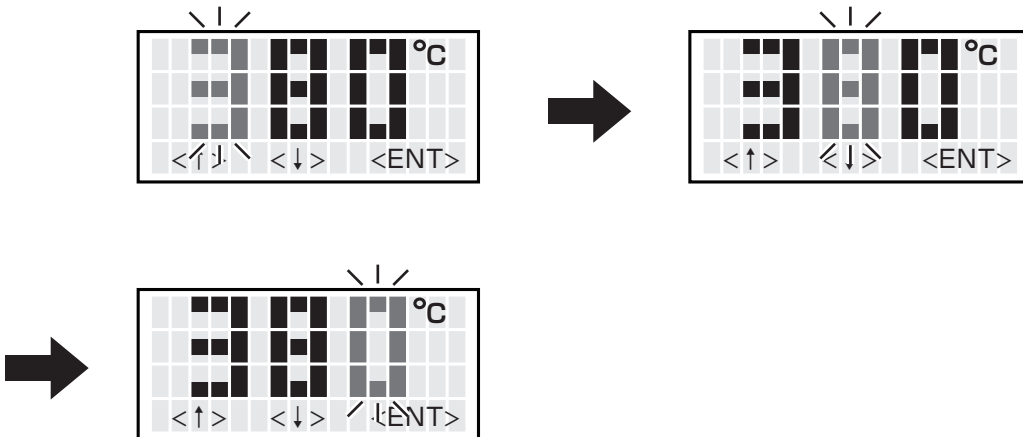

3. When desired figure is displayed, press the button to enter.

The next digit will begin to flash. After entering the units digit, press the button to save the figure to the system memory and begin heater control with new setting temperature.

⚠ CAUTION

If power is switched off or lost during the execution of this procedure, no data will be entered. The entire procedure must be repeated from step 1.

● Offset Temp

Example : If the measured temperature is 405°C and set temperature is 400°C, the difference is -5°C. (need to decrease by 5°C) So, enter the figure which 5 is deducted from present offset value.

1. Move the cursor to select "Offset Temp". After selecting, press <ENT>.

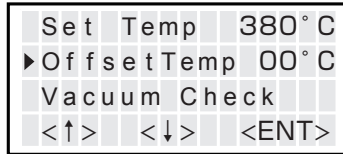

2. Enter the offset value (-5) which is the difference between tip temperature and set temperature.

The hundreds digit can display 0 (for positive value) or minus sign. (for negative value)
(Same values can be selected in °F mode.)

Values from 0 to 5 can be selected when entering the ten digit.

(In °F mode, values from 0 to 9 can be selected.)

Values from 0 to 9 can be selected when entering the units digit.

(Same values can be selected in °F mode.)

The allowable ranges for offset values are from -50 to +50°C . (In °F mode, from -90 to +90°F) If you enter a value outside the offset value range, the display returns to the hundreds digit, and you have to enter a correct value.

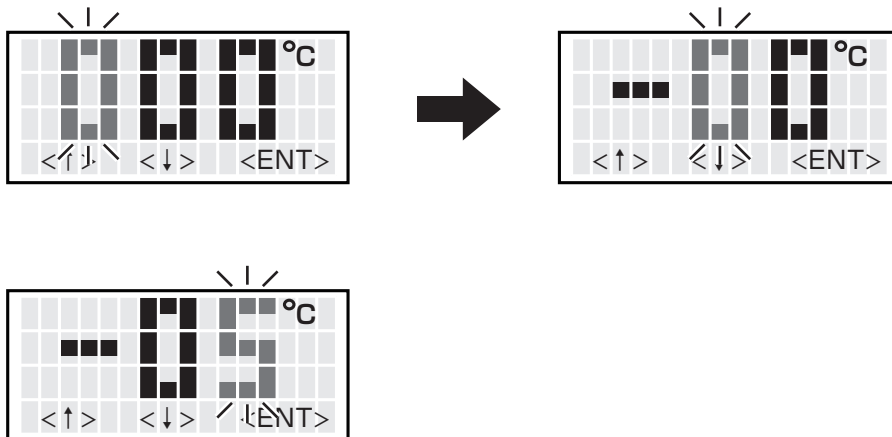

3. After entering the units digit, press the button to save the figure to the system memory and begin heater control with the new offset value.

⚠ CAUTION

During the offset setting, please be careful tip temperature does not exceed 450 °C.

● Vacuum Check

During suction, the gauge indicating sucking status is shown at the lower side of the screen.

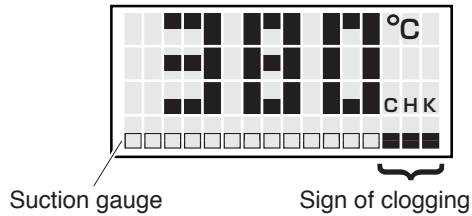

When “CHK” appears and you notice that the sucking force is weakening, perform “Vacuum Check.”

1. Move the cursor to select “Vacuum Check”. After selecting, press <ENT>.

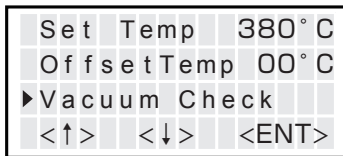

2. Pull the trigger.

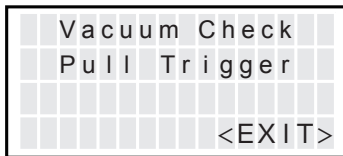

3. When “Clogging” appears, perform cleaning and replace filters.

No degradation in sucking force

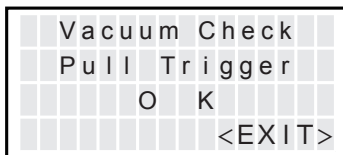

Degradation in sucking force

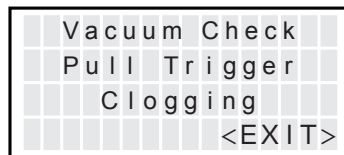

● Preset Temp

⚠ CAUTION

The temperature range is from 330 to 450°C. (620 to 850°F)

- If you enter a value outside the temperature setting range, the display returns to the hundreds digit, and you have to enter a correct value.

1. Move the cursor to select “Preset Temp”. After selecting, press <ENT>. Select the preset No. whose temperature setting you wish to change.

Offset Temp	00° C
Vacuum Check	
▶Preset Temp	
<↑>	<↓> <ENT>



Select the preset No.

▶P1 Temp	350° C
P2 Temp	400° C
P3 Temp	450° C
<↑>	<↓> <ENT>

2. Entering from hundreds to units digit
Press the <↑> or <↓> to set the desired figure.

Only values from 3 to 4 can be selected when entering the hundreds digit.

(In °F mode, values from 6 to 8 can be selected.)

Values from 0 to 9 can be selected when entering the tens or units digits.

(The same values can be selected in °F mode.)

PRESET1	TempSet
	350° C
<↑>	<↓> <ENT>



PRESET1	TempSet
	350° C
<↑>	<↓> <ENT>



PRESET1	TempSet
	350° C
<↑>	<↓> <ENT>

3. After entering the units digit, press the button to save the figure to the system memory and begin heater control with new setting temperature.

⚠ CAUTION

If power is switched off or lost during the execution of this procedure, no data will be entered. The entire procedure must be repeated from step 1.

4. To exit from each setting screen, scroll the screen, select <Exit>, and press the <ENT> button.

P2 Temp	400° C
P3 Temp	450° C
▶<EXIT>	
<↑>	<↓> <ENT>

● Preset ID

⚠ CAUTION

As a preset ID, 1 to 8 characters can be used.

Usable characters are “A-Z,” “0-9,” and space (“ ”). Entering a space makes your entry terminated. Any character(s) that follows the space is deleted.

1. Move the cursor to select “Preset ID”. After selecting, press <ENT>.

V	a	c	u	u		C	h	e	c	k		
P	r	e	s	e	t		T	e	m	p		
▶	P	r	e	s	e	t		I	D			
<	↑	>	<	↓	>	<	E	N	T	>		

2. Move up and down the cursor with the control buttons.
After selecting, press <ENT>.

▶	P	1		I	D		P	R	E	S	E	T	1
	P	2		I	D		P	R	E	S	E	T	2
	P	3		I	D		P	R	E	S	E	T	3
<	↑	>	<	↓	>	<	E	N	T	>			

3. Press the <↑> or <↓> to set the desired letters.

P	1		I	D						S	E	T
<	↑	>	<	↓	>	<	E	N	T	>		

4. To exit from setting screen, scroll the screen, select <EXIT>, and press the <ENT> button.

	P	2		I	D		P	R	E	S	E	T	2
	P	3		I	D		P	R	E	S	E	T	3
▶	<	E	X	I	T	>							
<	↑	>	<	↓	>	<	E	N	T	>			

● LCD Contrast

To make the screen display easy to see, adjust contrast.

1. Move the cursor to select "LCD Contrast". After selecting, press <ENT>.

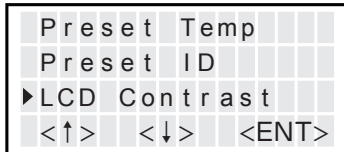

2. Press the <↑> or <↓> to set the adjust contrast.
(Selection range is 1 to 25.)

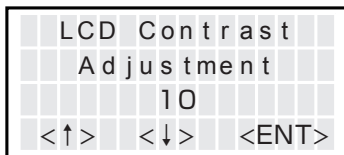

3. Press the <ENT> button to set the value.

To exit from each setting screen, scroll the screen, select <EXIT>, and press the <ENT> button.

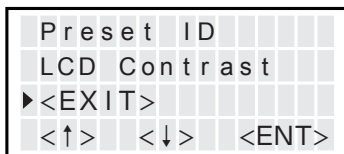

14. PARAMETER SETTING (Desoldering Tool)

● PARAMETER SETTINGS

Press and hold any one of the three control buttons, and turn on the power switch to display the parameter setting screen. The following parameters can be set:

Parameter name	Value	Initial value
Temp Mode	°C / °F	°C
ShutOff Set	OFF / ON	OFF
Timer*	30 ~ 60 min	30 min
Vacuum Mode	Normal / Timer	Normal
Vacuum Time**	1~5sec	1sec
Auto Sleep	OFF / ON	ON
Timer*	1 ~ 29min	6 min
Sleep Temp	200 ~ 300°C (390 ~ 570 °F)	200°C (390°F)
Low Temp	30 ~ 150°C (54 ~ 270°F)	150°C (270°F)
Error Alarm	ON / OFF	ON
Ready Alarm	ON / OFF	ON
Pass. Lock	ON (Lock / Partial) / OFF (unlock)	OFF
Password***	“ABCDEF” Select three letters	-
Initial Reset	°C / °F / Cancel	

* Auto-shutOff Time can be set when Auto-ShutOff is set to ON.

** Vacuum Time is displayed when Vacuum Mode is set to "Timer."

***Password is displayed when Password Lock is set to "ON" or "Partial."

● Temp Mode

The displayed temperature can be switched between Celsius and Fahrenheit.

1. Move the cursor to select “Temp Mode”.

After selecting, press <ENT>.

2. °C and °F will be switched alternately if you press the <↑> or <↓> button.

3. Return to parameter setting display if you press the <ENT> button after setting.

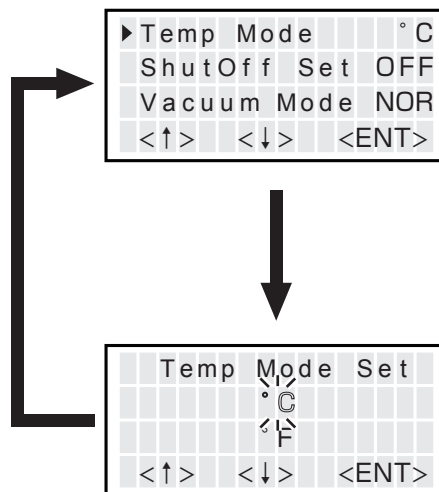

● ShutOff Set

Select whether you will activate the auto shut off function. When the auto shutoff function is set to on and no operation is performed for constant time after the iron is set in the iron holder, the buzzer sounds three times and the auto shutoff function will be enabled.

1. Move the cursor to select "ShutOff Set".
After selecting, press <ENT>.
2. ON and OFF will be switched alternately if you press the <↑> or <↓> button.
3. Selecting "ON" allows you to make the setting for "Timer."
(Default is 30 minutes.)
4. When setting "Shut Off" to "ON," the area for "Timer" flashes.
5. Press the <↑> or <↓> to set the desired figure.
6. Pressing the <ENT> button after this change makes the set time stored in the internal memory.

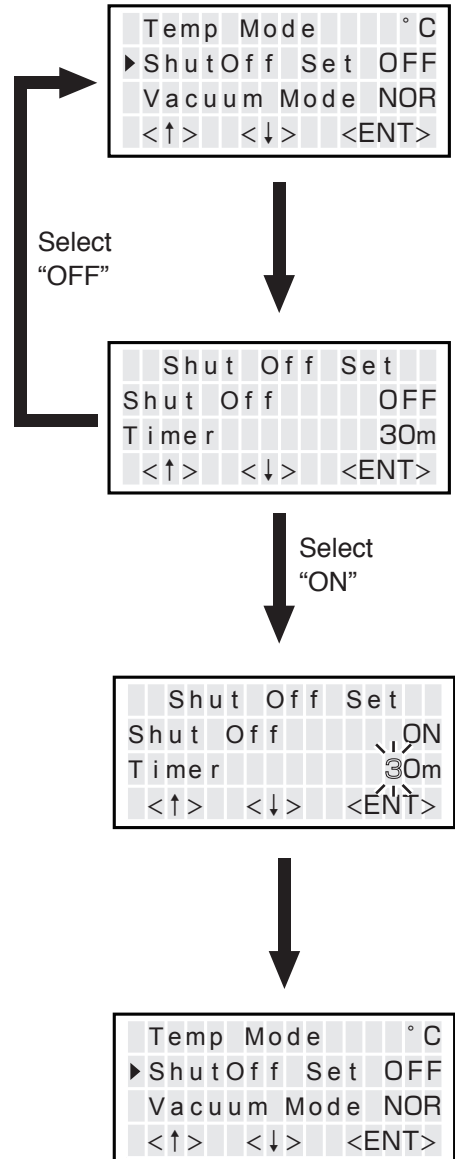

● Vacuum Mode

Select whether you manually operate the desoldering pump or use the timer function.

Normal : Solder is sucked only when you are pulling the trigger.

Timer : Even after you release the trigger, sucking continues for the specified period of time.

* Set time in "Vacuum Time."

1. Move the cursor to select "VacuumMode".
After selecting, press <ENT>.
2. Normal and Timer will be switched alternately if you press the <↑> or <↓> button.
3. Return to parameter setting display if you press the <ENT> button after setting.

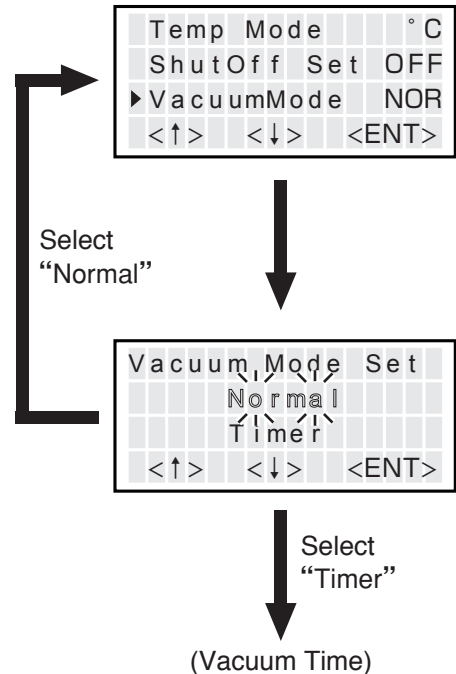

* When selecting Timer:

"Vacuum Time" appears under "Vacuum Mode" in the parameter select screen.

● Vacuum Time

1. Move the cursor to select "Vacuum Time".
After selecting, press <ENT>.
2. Press the <↑> or <↓> button, you can change to the desired value.
3. Return to parameter setting display if you press the <ENT> button after setting.

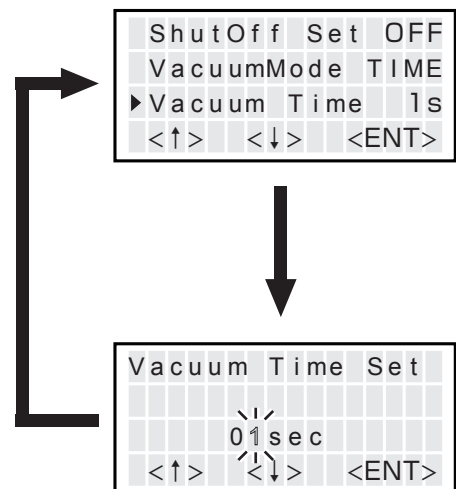

● Auto Sleep

Select whether you will activate the auto sleep function. When the auto sleep function is set to on and no operation is performed for constant time after the iron is set in the iron holder, the auto sleep function will be enabled.

* Set temp in “Sleep temp”.

1. Move the cursor to select “Auto Sleep”.
After selecting, press <ENT>.

ShutOff	Set	OFF
VacuumMode		NOR
▶Auto Sleep		OFF
<↑>	<↓>	<ENT>

2. ON and OFF will be switched alternately if you press the <↑> or <↓> button.

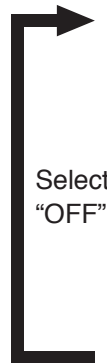

Auto Sleep	Set	
Auto Sleep		OFF
Timer		06m
<↑>	<↓>	<ENT>

3. Selecting “ON” allows you to make the setting for “Timer.”
(Default is 6 minutes.)

* When selecting “ON”

4. When setting “Auto Sleep” to “ON,” the area for Timer flashes.



Auto Sleep	Set	
Auto Sleep		ON
Timer		06m
<↑>	<↓>	<ENT>

5. Press the <↑> or <↓> button, you can change to the desired value.



ShutOff	Set	OFF
VacuumMode		NOR
▶Auto Sleep		06m
<↑>	<↓>	<ENT>

6. Pressing the <ENT> button after this change makes the set time stored in the internal memory.

● Sleep Temp

Sets the auto sleep temperature.

1. Move the cursor to select "Sleep Temp".
After selecting, press <ENT>.

VacuumMode	NOR
Auto Sleep	06m
▶ SleepTemp	200 °C
<↑>	<↓> <ENT>

2. Entering from hundreds to units digit.
Press the <↑> or <↓> to set the desired figure.

Only values from 2 to 3 can be selected when entering the hundreds digit.

(In °F mode, values from 3 to 5 can be selected.)

Values from 0 to 9 can be selected when entering the tens or units digits.

(The same values can be selected in °F mode.)

Sleep Temp Set
200 °C
<↑> <↓> <ENT>

3. After entering the units digit, press the button to save the figure to the system memory

● Low Temp

When the temperature drops below a set limit, an error is displayed and the buzzer sounds.

1. Move the cursor to select "Low Temp".
After selecting, press <ENT>.

Auto Sleep	06m
SleepTemp	200 °C
▶ Low Temp	150 °C
<↑>	<↓> <ENT>

2. Entering from hundreds to units digit.
Press the <↑> or <↓> to set the desired figure.

Only values from 0 to 1 can be selected when entering the hundreds digit.

(In °F mode, values from 0 to 2 can be selected.)

Values from 0 to 9 can be selected when entering the tens or units digits.

(The same values can be selected in °F mode.)

Low Temp Set
150 °C
<↑> <↓> <ENT>

3. After entering the units digit, press the button to save the figure to the system memory

● Error Alarm

In the buzzer sound setting mode, which sets whether to sound the buzzer when a error occurs.

1. Move the cursor to select "Error Alarm".
After selecting, press <ENT>.

SleepTemp	200°C
Low Temp	150°C
▶Error Alarm	ON
<↑>	<↓>
<ENT>	

2. ON and OFF will be switched alternately if you press the <↑> or <↓> button.

Error Alarm Set	
ON	
OFF	
<↑>	<↓>
<ENT>	

3. Return to parameter setting display if you press the <ENT> button after setting.

● Ready Alarm

When the set temperature alert setting mode is on, the buzzer sounds if you reached the usable temperature.

1. Move the cursor to select "Ready Alarm".
After selecting, press <ENT>.

Low Temp	150°C
Error Alarm	OFF
▶Ready Alarm	ON
<↑>	<↓>
<ENT>	

2. ON and OFF will be switched alternately if you press the <↑> or <↓> button.

Ready Alarm Set	
ON	
OFF	
<↑>	<↓>
<ENT>	

3. Return to parameter setting display if you press the <ENT> button after setting.

● Pass. Lock

When enabling this function, you must enter a correct password to change a setting. The options are as follows:

Lock : All setting changes require a password entry.

Partial : Selection of whether or not to enter a password when changing set temperature, preset selection, and offset temperature. All other setting changes require a password entry.

Unlock : Any setting change does not require a password entry.

1. Move the cursor to select "Pass. Lock".
After selecting, press <ENT>.

2. Using the <↑> or <↓> button, select an option from Lock, Partial, and Unlock.

* When selecting Partial or Lock:

3. Specify whether password lock should be enabled when changing set temperature, preset selection, and offset temperature by selecting ON or OFF. (Only when selecting Partial)

4. After making all selections, press the <ENT> button. (Only when selecting Partial)

5. Using the <↑> or <↓> button, enter a password. (Selection of three characters from ABCDEF)

6. Return to parameter setting display if you press the <ENT> button after setting.

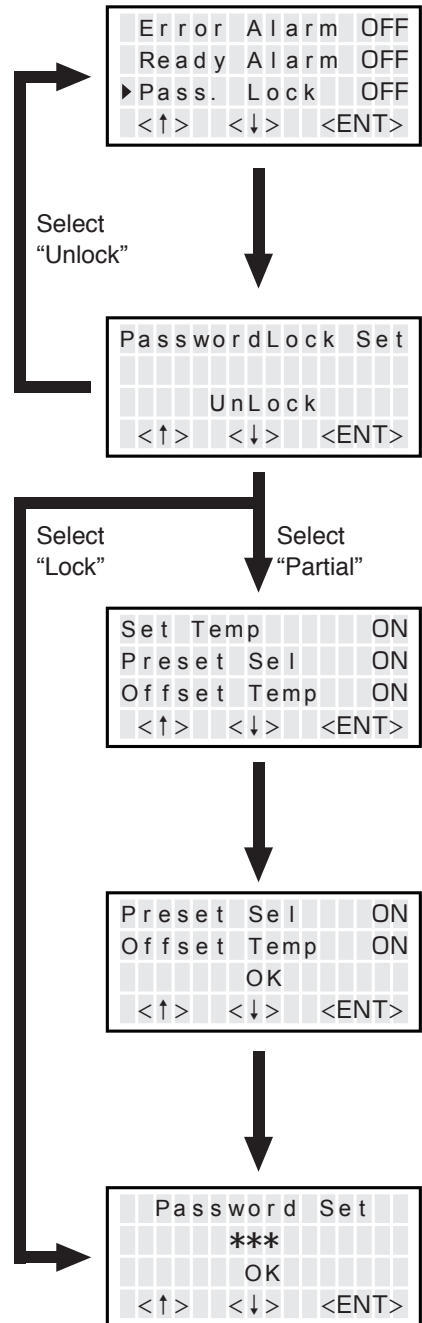

● Initial Reset

Initial Reset allows the factory default settings to be restored.

1. Move the cursor to select “Initial Reset”.

After selecting, press <ENT>.



2. Using the <↑> or <↓> button, select either C or F. To stop Initial Reset, scroll the screen to select <Exit>.

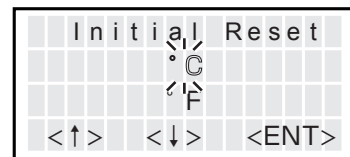

3. After selecting it, using the <↑> or <↓> button, select OK or Cancel.

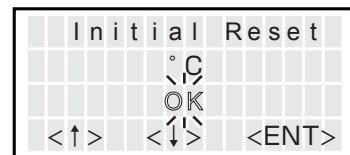

⚠ CAUTION

Even when Initial Reset is finished, “Pass. Lock” and password settings remain.

After completing settings, if you press the “ENT” button again in the selection screen, you will return to the normal display.

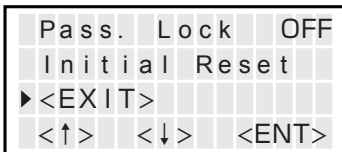

15. MAINTENANCE (Desoldering Tool)

Properly maintained, the HAKKO FR-701 (Desoldering tool) should provide years of good service. Efficient desoldering depends upon the temperature, nozzle selection, and proper routine maintenance. Perform the following service procedures as dictated by the conditions of the station's usage.

⚠ WARNING

Since the desoldering tool can reach a very high temperature, please work carefully. Except when cleaning the nozzle and heating element, ALWAYS turn the power switch OFF and disconnect the power plug before performing any maintenance procedure.

During suction, the gauge indicating suction force is shown at the bottom of the screen.

If "CHK" appears on the display, check the nozzle and heater for restrictions.

If the nozzle or heater are clogged, clean or replace them.

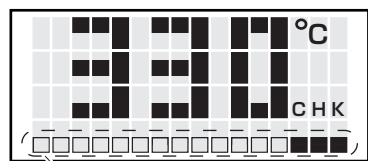

Suction gauge Sign of clogging

Replacing the filter

Replace the filter as shown following steps A to C. During operation, the filter pipe is very hot. Wait until the filter pipe is cool before replacing the filter or cleaning.

We recommend keeping a second filter pipe containing new filters handy, and replacing the installed filter pipe with this secondary filter pipe.

C. Replace the entire filter pipe with a secondary filter pipe.

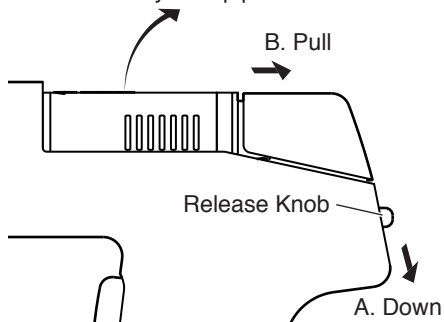

⚠ CAUTION

The section from the heating element to the filter pipe is provided with pipes through which melted solder passes, so it may become very hot. Be very careful when handling this section.

CAUTION : HOT AREA

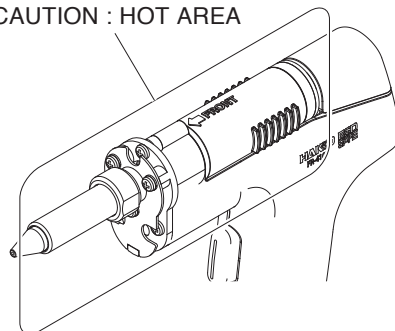

Nozzle Maintenance

⚠ CAUTION

The desoldering tool may be extremely hot. During maintenance, please work carefully.

1. Inspect and clean the nozzle

- Turn the power switch ON and let the nozzle heat up.

⚠ CAUTION

The cleaning pin will not pass through the nozzle until the solder inside the nozzle is completely melted.

- Clean out the hole of the nozzle with the nozzle cleaning pin.
- If the cleaning pin does not pass through the hole in the nozzle, clean with the cleaning drill.
- Check the condition of the solder plating on the nozzle tip.

⚠ CAUTION

If the cleaning drill is forced into the nozzle, the drill bit could break or be damaged. Please use the proper size cleaning pin or cleaning drill for the nozzle diameter.

- Check visually if the nozzle was eroded.

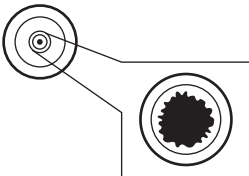

Hole is damaged by erosion.

- If the cleaning pin and cleaning drill do not pass through the hole in the nozzle, replace the nozzle.
- If the solder plating on the nozzle tip is worn, replace the nozzle.
- If the inside hole of the nozzle is eroded, replace the nozzle.

⚠ CAUTION

Desoldering efficiency goes down and all other parts appear to be OK, the nozzle is probably eroded and should be replaced.

The inside hole and the surface of the nozzle is plated with a special alloy. Should this alloy become eroded by high temperature solder, the nozzle will not be able to maintain the proper temperature.

- If the nozzle is still in a good condition, put some fresh solder on the nozzle tip to protect solder plated area from oxidation.

Cleaning with the nozzle cleaning pin

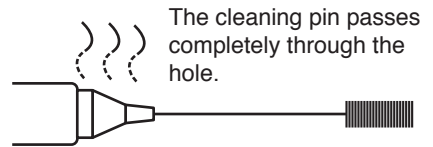

Cleaning with the cleaning drill

- Before cleaning

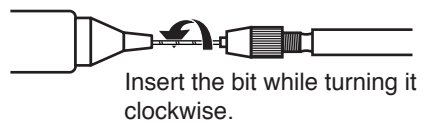

- After cleaning

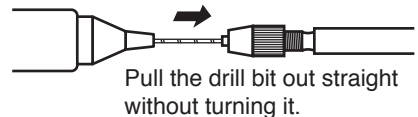

Use the proper size cleaning pin or cleaning drill for the nozzle diameter.

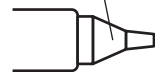

2. Disassemble the heating element.

Remove the element cover assembly and the nozzle with the provided wrench.

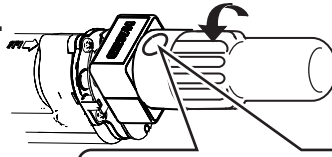

⚠ CAUTION

The heating element is very hot during operation.

The element cover assembly is held to the nozzle changing tool by pressing this part from both sides. (The nozzle is not held to the nozzle changing tool. Be careful when removing them.)

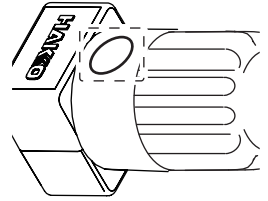

Heating Element

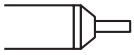

Nozzle

Element cover



Nut

3. Clean out the tube in the heating element with the provided cleaning pin.

- Turn the power off after cleaning.

Scrape away all oxidation from the tube in the heating element until the cleaning pin passes cleanly through the tube.

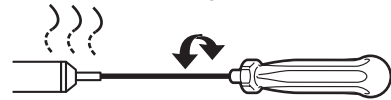

⚠ CAUTION

- Be sure the solder in the tube in the heating element is completely heated, before cleaning the tube.
- If the cleaning pin does not pass through the tube in the heating element, replace the heating element.

4. Replace the filters.

- Turn the power switch OFF.
- When the filter pipe is cool to the touch, push down on the release knob at the back of the handpiece and remove the filter pipe.

⚠ CAUTION

The filter pipe is very hot.

- Examine the seals (front and filter holders) at each end of the filter pipe.
Replace : Stiff and/or cracked.
- Examine the Pre-filter: Remove solder adhering to the waste collector.
- Examine the ceramic paper filter (L).
Replace : Ceramic paper filter (L) is showing signs of stains from flux, is stiff, or contains any solder.

Front holder

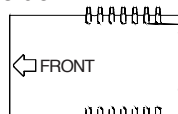

Pre-filter

Filter holder

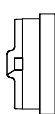

Ceramic paper filter (L)

5. Replacement of station filter

If the filter is showing signs of stains from flux or is stiff, replace it. Attach the filter as shown in the right diagram.

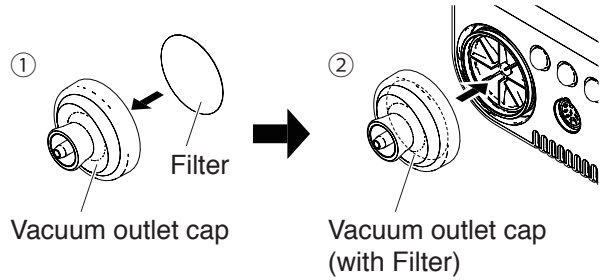

Replacing the heating element (heating core)

⚠ CAUTION

Except the case especially indicated, always turn the power switch OFF and disconnect the power plug before performing any maintenance procedure.

● Disassemble the heating element.

1. Remove the nozzle and tip enclosure.

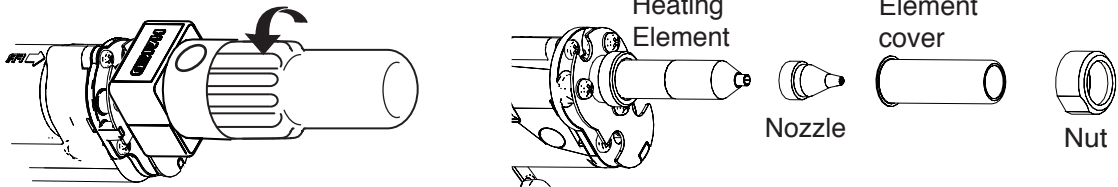

Remove the tip enclosure and the nozzle with the attached wrench.

2. Remove the 3 screws from the handpiece and disconnect the heating element.

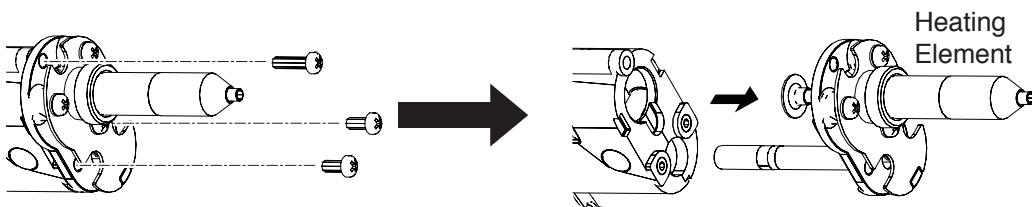

3. Replace the heating element. Assemble using the same procedure in reverse.

⚠ CAUTION

Be sure to calibrate the nozzle temperature after replacing the heating element. Failure to do this may result in a heater temperature that is much higher or lower than the previous one.

Maintenance of the pump head

● Remove the cover

When performing maintenance on the pump head, remove the screws holding the cover and take the cover off.

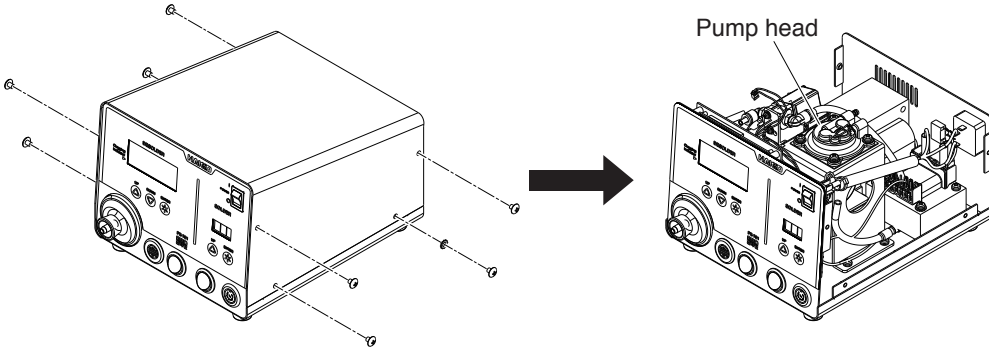

● Cleaning the pump head

1. Remove the valve and valve guard and remove any attached flux.

⚠ CAUTION

- When the valve guard is difficult to remove, please warm it with hot air. Please do not try to forcibly remove it with a screwdriver, etc. If the valve guard becomes deformed, it will no longer be airtight.
- Please clean with either alcohol or thinner.

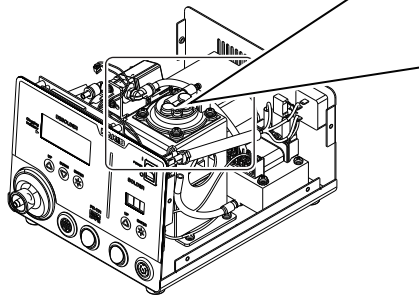

Pump head disassembly
*It is resting on its side.
Clean the pump head, valve
and valve guard.

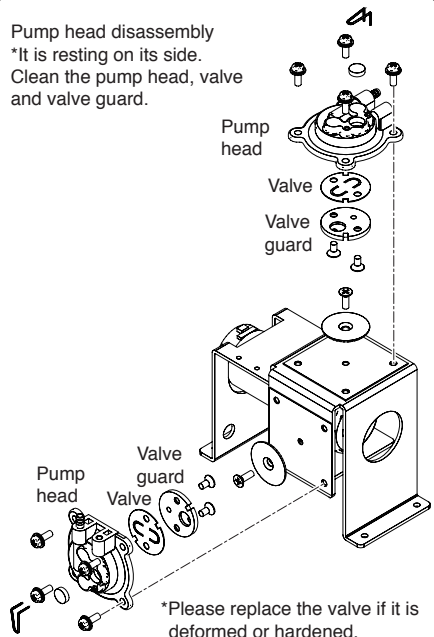

2. Install the valve and valve guard.

⚠ CAUTION

When assembling the pump, please make sure to keep it airtight so that there are no air leaks.

16. CHECKING PROCEDURE (Desoldering Tool)

⚠ WARNING

Unless otherwise directed, carry out these procedures with the power switch OFF and the power UNPLUGGED.

■ Check for a broken heater or sensor

1. Check for a broken heater or sensor

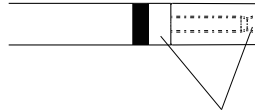

Measure the resistance across this position.

Verify the electrical integrity of the heater and sensor.

Measure the resistance of the heater and sensor while at room temperature (15~25°C ; 59~77°F) . It should be $3.9 \Omega \pm 10\%$. If the resistance exceeds these limits, replace the tip.

■ Replacing the fuse

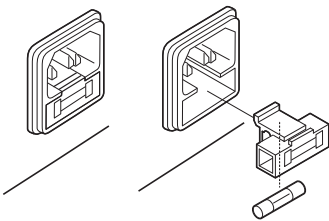

1. Unplug the power cord from the power receptacle.
2. Remove the fuse holder.
3. Replace the fuse.
4. Put the fuse holder back in place.

■ Checking the connection cord for breakage

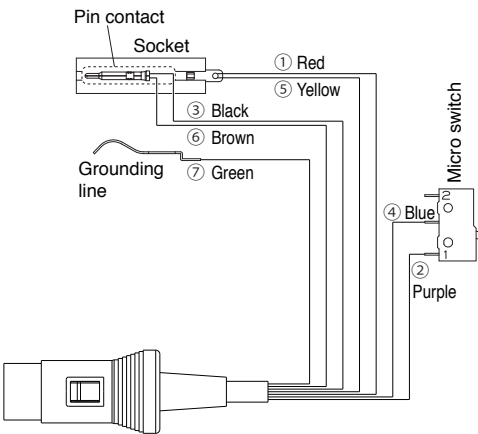
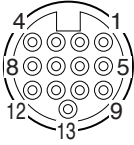

Checking the connection cord for breakage

1. Unplug the connection cord from the station.
2. Disassemble the heating element. {Please refer to [Replacing the heating element (heating core)]}
3. Measure the resistance values between the connector and the lead wires at the socket as follows:

Pin1	·····	Red {Heating element1 (+)}	①
Pin2	·····	Purple {Trigger (+)}	②
Pin4	·····	Black {Heating element 1 (-)}	③
Pin8	·····	Blue {Trigger (-)}	④
Pin9	·····	Yellow {Heating element2 (+)}	⑤
Pin12	·····	Brown {Heating element2 (-)}	⑥
Pin13	·····	Green (Grounding line)	⑦*

If any value exceeds 0Ω or is ∞ , replace the connection cord.

* For information on the plug 13, refer to “■ Checking the grounding line”

■ Checking the grounding line

1. Measure the resistance value between Pin 13 and the nozzle.
2. If the value exceeds 2Ω (at room temperature), perform the nozzle maintenance. If the value still does not decrease, check the connection cord for breakage.

18. TROUBLE SHOOTING GUIDE

⚠ WARNING

Before checking the inside of the HAKKO FR-701 or replacing parts, be sure to disconnect the power plug.

● Nothing happens when the power switch is turned on.

CHECK : Is the power cord and/or connecting plug disconnected?

ACTION : Connect it.

CHECK : Is the fuse blown?

ACTION : Determine why the fuse blew and eliminate the cause, then replace the fuse.

a. Is the inside of the iron short-circuited?

b. Is the grounding spring touching the heating element?

c. Is the heating element lead twisted and short-circuited?

Try replacing the fuse even if the cause cannot be identified.

If it still blows, return the product for repair.

● The heater lamp lights up but the tip does not heat up. (Soldering iron)

CHECK : Is the cord assembly broken? Is the heating element/sensor broken?

ACTION : If the cord assembly is broken, replace the HAKKO FX-8801.

If the heating element / sensor is broken, replace the heating element.

● The Heater-error **H-E** is displayed. (Soldering iron)

CHECK : Is the heater broken?

ACTION : If the heater is broken, replace the heating element.

CHECK : Is the setting value for the low-temperature alarm tolerance too low?

ACTION : Increase the setting value.

● The tip heats up intermittently. (Soldering iron)

CHECK : Is the cord assembly broken?

ACTION : If the cord assembly is broken, replace the HAKKO FX-8801.

● Solder does not wet to the tip or nozzle.

CHECK : Is the tip or nozzle temperature too high?

ACTION : Set an appropriate temperature.

CHECK : Is the tip coated with black oxide?

ACTION : Remove the black oxide. (Refer to "Tip Maintenance.")

● The tip or nozzle temperature is too low.

CHECK : Is the tip or nozzle coated with black oxide?

ACTION : Remove the black oxide. (Refer to "Tip Maintenance.")

CHECK : Is the iron temperature adjusted correctly?

ACTION : Perform the temperature adjustment.

● The tip can not be pulled off. (Soldering iron)

CHECK : Is the tip seized? Is the tip swollen because of deterioration?

ACTION : Replace the tip and the heating element.

● The tip or nozzle doesn't hold the desired temperature.

CHECK : Is the iron temperature adjusted correctly?

ACTION : Perform the temperature adjustment.

● Pump does not operate. (Desoldering Tool)

CHECK : Is the power supply cable or connection plug disconnected?

ACTION : Connect it tightly.

CHECK : Is the heater tube or nozzle clogged?

ACTION : Clean it.

● Solder is not being absorbed. (Desoldering Tool)

CHECK : Is the filter pipe full of solder?

ACTION : Clean it.

CHECK : Is the ceramic paper Filter (L) hardened?

ACTION : Replace it with a new one.

CHECK : Is there a vacuum leak?

ACTION : Check the connections and filter pipe seals and replace any worn parts.

CHECK : Is the heater tube or nozzle clogged?

ACTION : Clean it.

● The nozzle does not heat up. (Desoldering Tool)

CHECK : Is the desoldering gun cord assembly properly connected?

ACTION : Connect it tightly.

CHECK : Is the heating element damaged?

ACTION : Replace it with a new one.

NOTE :

When repairs are needed, please send both the handpiece and the station to your sales agent.

19. TIP & NOZZLE STYLES

Unit : mm

● Tip

T18-B SHAPE-B

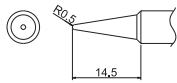

T18-C05 SHAPE-0.5C

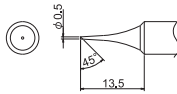

T18-C1 SHAPE-1C
T18-CF1*

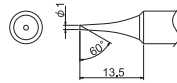

T18-C2 SHAPE-2C
T18-CF2*

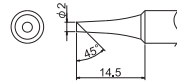

T18-C3 SHAPE-3C
T18-CF3*

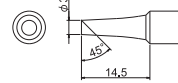

T18-D08 SHAPE-0.8D

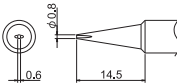

T18-D12 SHAPE-1.2D

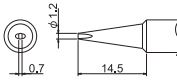

T18-D16 SHAPE-1.6D

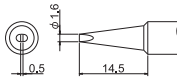

T18-D24 SHAPE-2.4D

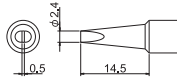

T18-I SHAPE-I

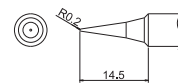

T18-K SHAPE-K

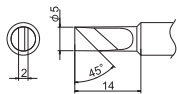

* Tinned on the soldering surface only.

● Use only genuine Hakko soldering iron tips. Replacement tips for the HAKKO FX-8801 are designated the T18 series.

● Nozzle

N61-01

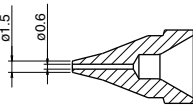

N61-02

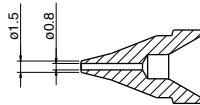

N61-03

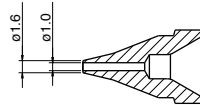

N61-04

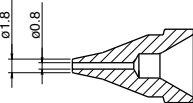

N61-05

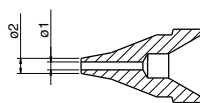

N61-06

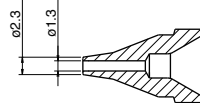

N61-07

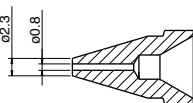

N61-08

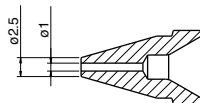

N61-09

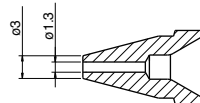

N61-10

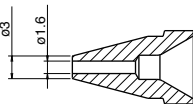

N61-11

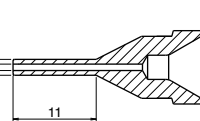

N61-12

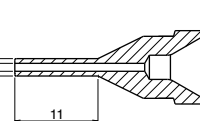

N61-13

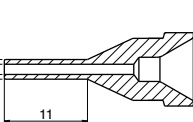

N61-14

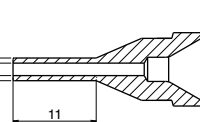

N61-15

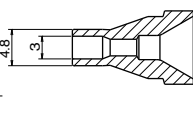

N61-16

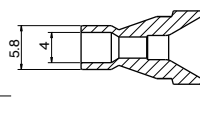

20. PARTS LIST

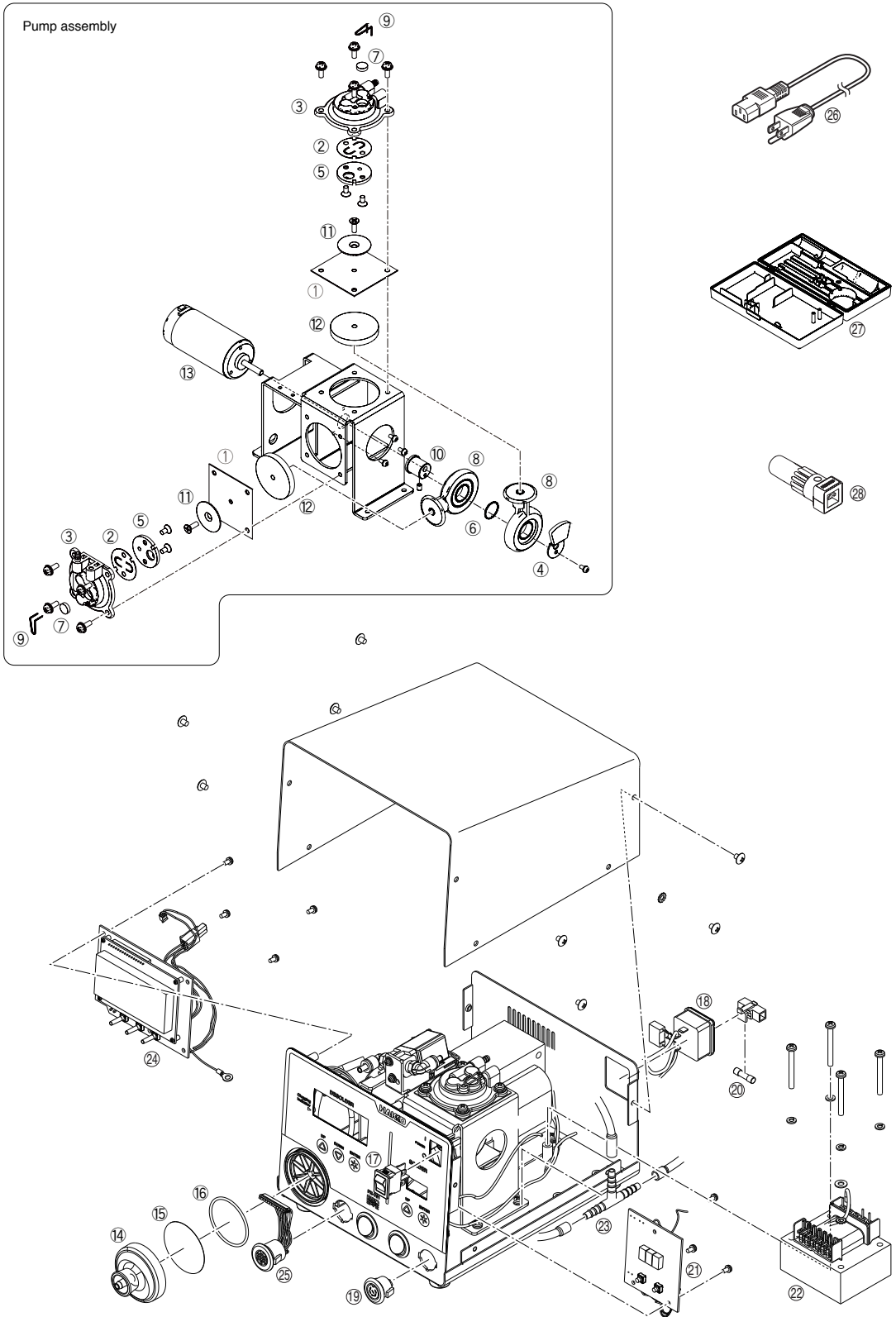



● HAKKO FR-701

Item No.	Part No.	Part Name	Specifications
①	A1013	Diaphragm	2 pcs.
②	A1014	Valve plate	2 pcs.
③	B1050	Pump head	
④	B1053	Balance weight	
⑤	B1056	Fixing plate	
⑥	B1057	Ring for bearing	
⑦	B1059	Exhaust filter	2 pcs.
⑧	B1312	Crank	
⑨	B1313	Filter retaining pin	
⑩	B2060	Crank shaft	
⑪	B2085	Diaphragm setting plate	
⑫	B2506	Damper	2 pcs.
⑬	B3428	Motor	
⑭	B5076	Vacuum outlet cap	
⑮	A5020	Filter	Set of 10
⑯	B5077	O-ring / S-40	for vacuum outlet retainer
⑰	B5148	Power switch	
⑱	B2384	Inlet	
⑲	B3463	Receptacle	Soldering iron
⑳	B3674	Fuse/250V-7A	100 - 110V
	B3675	Fuse/250V-4A	220 - 240V
㉑	B3736	P.W.B. / for control	Soldering iron
㉒	B3737	Transformer	100 -110V Soldering iron
	B3739	Transformer	220 -240V Soldering iron
㉓	B3414	Inner hose joint	
㉔	B5176	P.W.B. / for control	Desoldering Tool
㉕	B5100	Receptacle assembly	Desoldering Tool

Item No.	Part No.	Part Name	Specifications
㉖	B2421	Power cord, 3 wired cord but no plug	220-240V
	B2422	Power cord, 3 wired cord & BS plug	India
	B2424	Power cord, 3 wired cord & European plug	220V KTL, 230V CE
	B2425	Power cord, 3 wired cord & BS plug CE	230V CE, U.K
	B2426	Power cord, 3 wired cord & Australian plug	
	B2436	Power cord, 3 wired cord & Chinese plug	China
	B3508	Power cord, 3 wire cord & American plug	
	B3550	Power cord, 3 wire cord & SI plug	
㉗	C5030	Tool box	
㉘	B5106	Nozzle wrench	

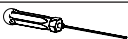
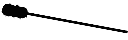
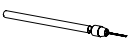
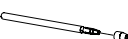
● Cleaning pin / Drill

	Part No.	Part Name	Specifications
	B1215	Cleaning pin	For heating element
	B2874	Cleaning pin	For ø0.6 mm (0.02 in.) nozzle
	B1086	Cleaning pin	For ø0.8 mm (0.03 in.) nozzle
	B1087	Cleaning pin	For ø1.0 mm (0.04 in.) nozzle
	B1088	Cleaning pin	For ø1.3 mm (0.05 in.) nozzle
	B1089	Cleaning pin	For ø1.6 mm (0.06 in.) nozzle
	B5141	Cleaning drill	For ø0.6 mm (0.02 in.) nozzle
	B1302	Cleaning drill	For ø0.8 mm (0.03 in.) nozzle
	B1303	Cleaning drill	For ø1.0 mm (0.04 in.) nozzle
	B1304	Cleaning drill	For ø1.3 mm (0.05 in.) nozzle
	B1305	Cleaning drill	For ø1.6 mm (0.06 in.) nozzle
	B5142	Drill holder	For ø0.6 mm (0.02 in.) nozzle
	B1306	Drill holder	For ø0.8 mm (0.03 in.)/1.0 mm (0.04 in.) nozzle
	B1307	Drill holder	For ø1.3 mm (0.05 in.)/1.6 mm (0.06 in.) nozzle
	B5143	Drill bit	For ø0.6 mm (0.02 in.) nozzle (set of 10)
	B1308	Drill bit	For ø0.8 mm (0.03 in.) nozzle (set of 10)
	B1309	Drill bit	For ø1.0 mm (0.04 in.) nozzle (set of 10)
	B1310	Drill bit	For ø1.3 mm (0.05 in.) nozzle (set of 10)
	B1311	Drill bit	For ø1.6 mm (0.06 in.) nozzle (set of 10)

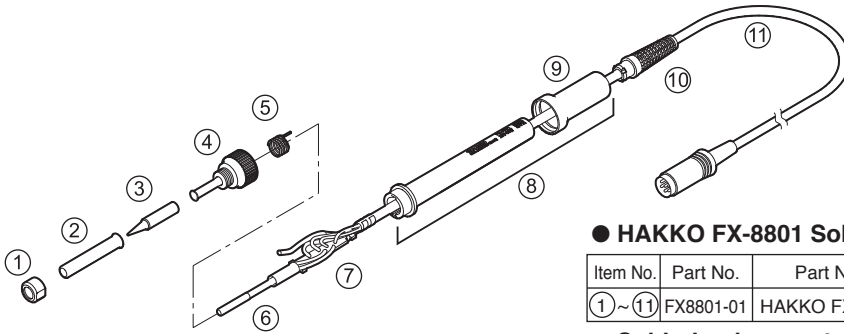

● HAKKO FX-8801 Soldering iron

Item No.	Part No.	Part Name	Specifications
①~⑪	FX8801-01	HAKKO FX-8801	

● Soldering iron parts

Item No.	Part No.	Part Name	Specifications
①	B1785	Nut	
②	B3469	Tip enclosure	
③		Tip	See "19. TIP & NOZZLE STYLES"
④	B2022	Nipple	
⑤	B2032	Grounding spring	
⑥	A1560	Heating element	26V-65W
⑦	B2028	Terminal board	with cord stopper
⑧	B3470	Handle	with handle cover
⑨	B3471	Handle cover	
⑩	B3467	Cord bushing	
⑪	B3468	Cord assembly	

● Optional parts

Item No.	Part No.	Part Name	Specifications
①	B5122	Tip enclosure assembly	

* If you use the capacious tip T19, change to above tip enclosure assembly. Please see the tip styles and tip shape for T19 from the following URL.

⇒ <http://www.hakko.com>

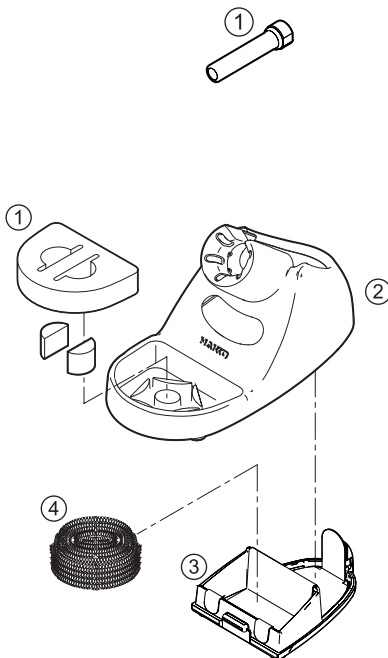

● HAKKO FH-800 Iron holder

Item No.	Part No.	Part Name	Specifications
①~⑤	FH800-03BY	HAKKO FH-800	Blue-Yellow

● Iron holder parts

図番	Part No.	Part Name	Specifications
①	A1559	Cleaning sponge	
②	B3472	Iron holder base	BY with rubber foot
③	B3751	Bottom plate	with Protective Sheet & rubber foot
④	A1561	Cleaning wire	

⚠ CAUTION

For safety reasons, please attach the protective sheet to the bottom plate when using the soldering iron.



● Optional parts

Part No.	Part Name	Specifications
B3474	Rubber cleaner	

● HAKKO FR-4101

Part No.	Part Name	Specifications
FR4101-81	HAKKO FR-4101	Gun type

● HAKKO FR-4101 parts

Item No.	Part No.	Part Name	Specifications
①	A5030	Front holder	
②	B5104	Pre-filter	
③	A5031	Filter holder	
④	A1033	Ceramic paper filter (L)	Set of 10
①-④	B5105	Filter pipe assembly	
⑤	B5102	Nut	
⑥	B5103	Element cover	
⑦	A5028	Heating element	
⑧	B5101	Hose	
⑨	B2953	Cord holder	Set of 4

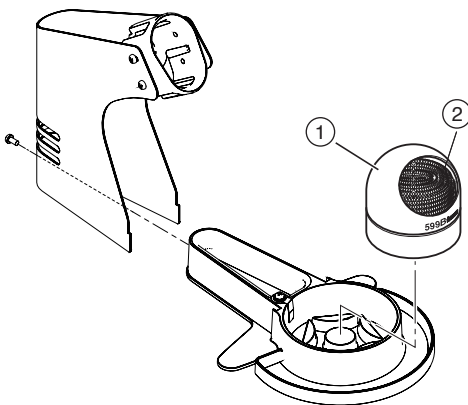
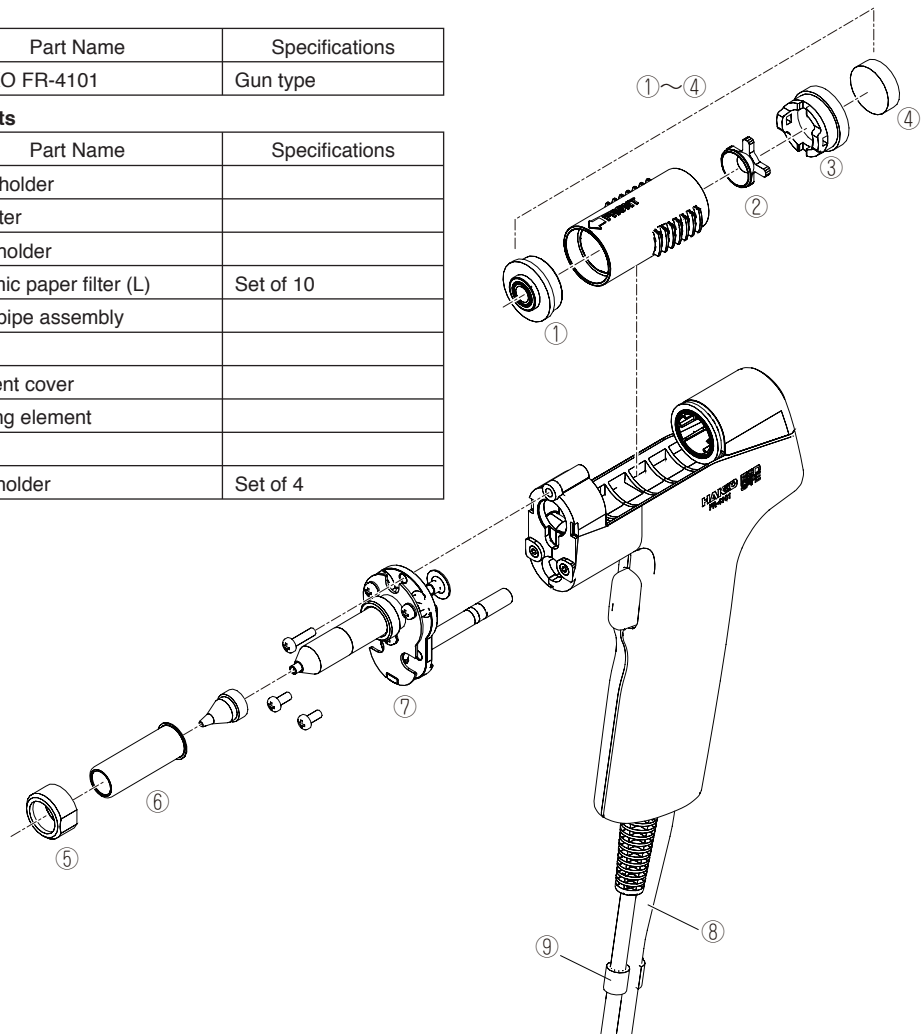

● Iron holder

Part No.	Part Name	Specifications
FH410-82	Iron holder	with cleaning wire

● Iron holder parts

Item No.	Part No.	Part Name	Specifications
①	FT400-81	Tip cleaner	
②	599-029	Cleaning wire	

21. WIRING DIAGRAM

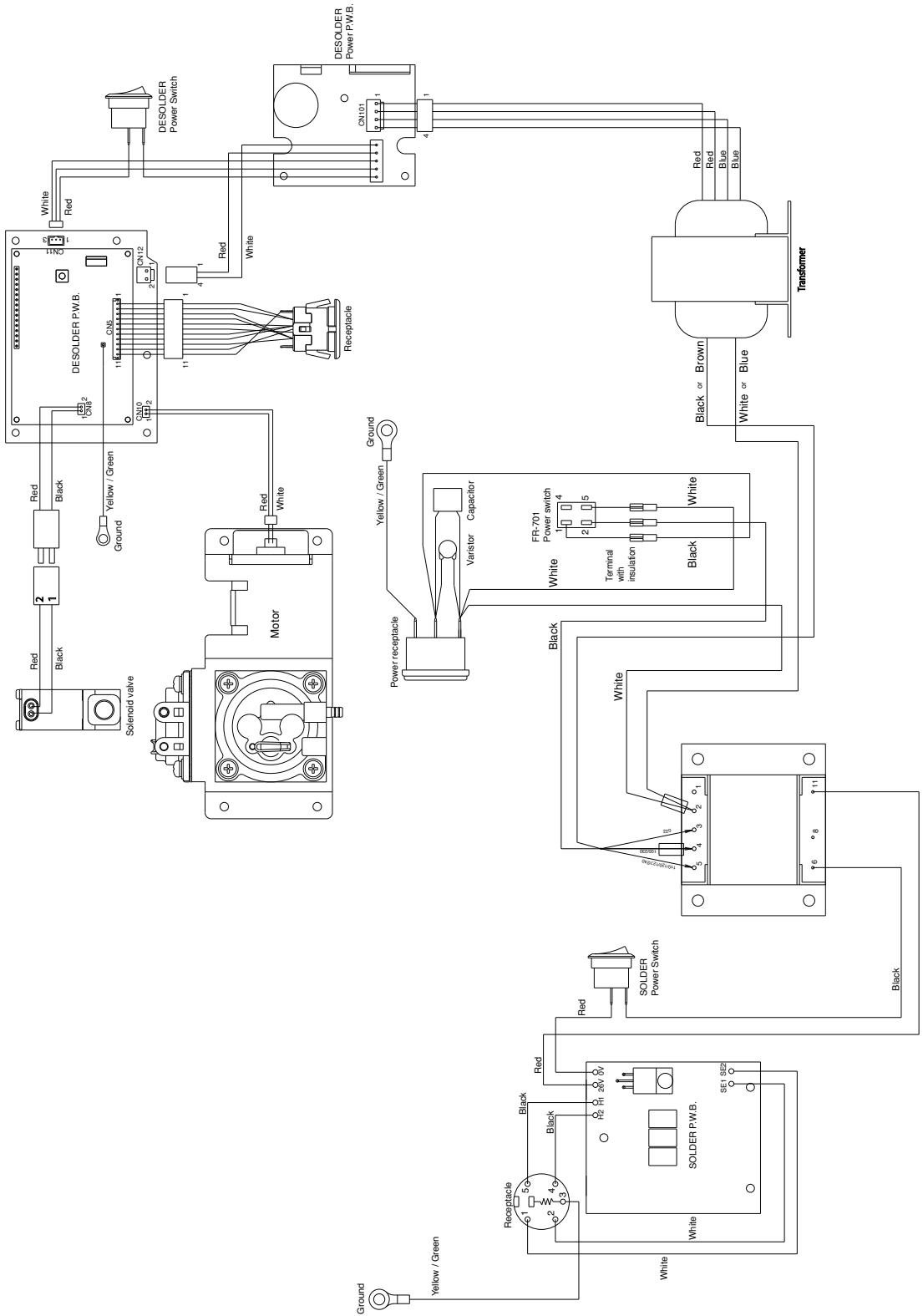

MEMO



HAKKO CORPORATION

HEAD OFFICE

4-5, Shiokusa 2-chome, Naniwa-ku, Osaka 556-0024 JAPAN

TEL:+81-6-6561-3225 FAX:+81-6-6561-8466

<http://www.hakko.com> E-mail:sales@hakko.com

OVERSEAS AFFILIATES

U.S.A.: AMERICAN HAKKO PRODUCTS, INC.

TEL: (661) 294-0090 FAX: (661) 294-0096

Toll Free (800)88-HAKKO

<http://www.hakkousa.com>

HONG KONG: HAKKO DEVELOPMENT CO., LTD.

TEL: 2811-5588 FAX: 2590-0217

<http://www.hakko.com.hk>

E-mail:info@hakko.com.hk

SINGAPORE: HAKKO PRODUCTS PTE., LTD.

TEL: 6748-2277 FAX: 6744-0033

<http://www.hakko.com.sg>

E-mail:sales@hakko.com.sg

Please access to the following address for the other Sales affiliates.

<http://www.hakko.com>